

PloK[®]

Rapid Mating Multi-Pin Industrial Connector



Amphenol
Industrial

Sine Systems * Pyle Connectors Corporation

Contents

- Features/Benefits _____ 1-2
- Insert Configuration _____ 3-7
- Engineering Data _____ 8
- Product Ordering Guide _____ 9
- Dimensional Information _____ 10-13
- Tools & Replacement Contacts _____ 14
- Assembly Instructions _____ 15-16
- Product Information _____ 17



Features and Benefits



- Rapid mate spring loaded , push to mate, pull to unmate coupling system
- Audible & tactile conformation of positive locking connection
- Eliminates problems inherent in threaded connectors such as cross threading, improper mating & loose connections
- Insert arrangements available in 2 - 26 conductor arrangements

Amphenol Industrial Sine System Pyle Connectors Corporation P-lok® connectors are rapid mating multi-pin connectors, engineered to provide reliable yet convenient electrical connections for a wide variety of industrial and commercial applications. P-lok connectors may be implemented where threaded Mil-C-5015 connectors or their commercial equivalents might be specified. P-lok features the same electrical characteristics as Mil-C-5015 connectors and approximately the same physical size allowing for easy conversion from the threaded style connectors to Sine P-lok. P-lok however is not intermatable with Mil-C-5015 connectors.

P-lok's most exciting feature is its rapid mating coupling system. This connector creates a positive locking action of the plug and receptacle through the use of a spring loaded coupling ring on the plug and stainless steel ball bearings on the receptacle. This system is similar to the coupling system that is employed on pneumatic hose connections. This coupling design has proven to be reliable, positive and simple to use. Align the single keyway on the plug to the key on the receptacle and push the halves together to create a locked, mated connection. The connection is confirmed through tactile feel and audible snap, creating a positive lock that stays mated. To disengage the connection simply pull back on the plug's coupling ring, separating the connector halves. P-lok is reliable and eliminates all the issues that are inherent with Mil-C-5015 threaded connectors.

P-lok connectors are manufactured from machined aluminum and finished in black hard coat, providing a strong industrial grade connector that has been engineered for a long service life. Everything about P-lok's construction is more advanced than the similar threaded connectors. This allows P-lok connectors to excel in applications where threaded connectors do not.

P-lok is an environmentally sealed connector system that is rated to IP65 specification. The sealing features of P-lok connectors include an o-ring seal at the rear of the coupling ring, and a corresponding o-ring seal on the receptacle that seals the front of the coupling ring. There is a tapered compression grommet that creates a seal around the cable jacket.

P-lok allows for a variety of connector hardware and strain relief options. Plugs can be male or female with straight or right angle cable adapters with cable clamp, compression grommet or compression grommet with basketweave. This allows the design engineer to choose the style required to meet any specification. Receptacles are also available in male or female panel mount or in-line styles with the same cable adapter and strain relief options as used on the plugs.



P-lok inserts and contacts incorporate proven electrical characteristics and reliability based on Mil-C-5015 specifications. These machined contacts are available for 16, 12, 8 and 4 gauge wire in both crimp or solder styles with silver or gold plated finishes. The contacts are secured in Neoprene®* inserts that have been bonded to the connector shell providing ease of connector assembly. Inserts are manufactured in multiple arrangements including power, signal and mixed insert configurations, allowing for flexibility in application.

P-lok connectors have been proven in a wide variety of applications, motion control & vision systems, photographic lighting equipment, industrial controls, communications or any application that requires a quality connector that mates rapidly and positively.

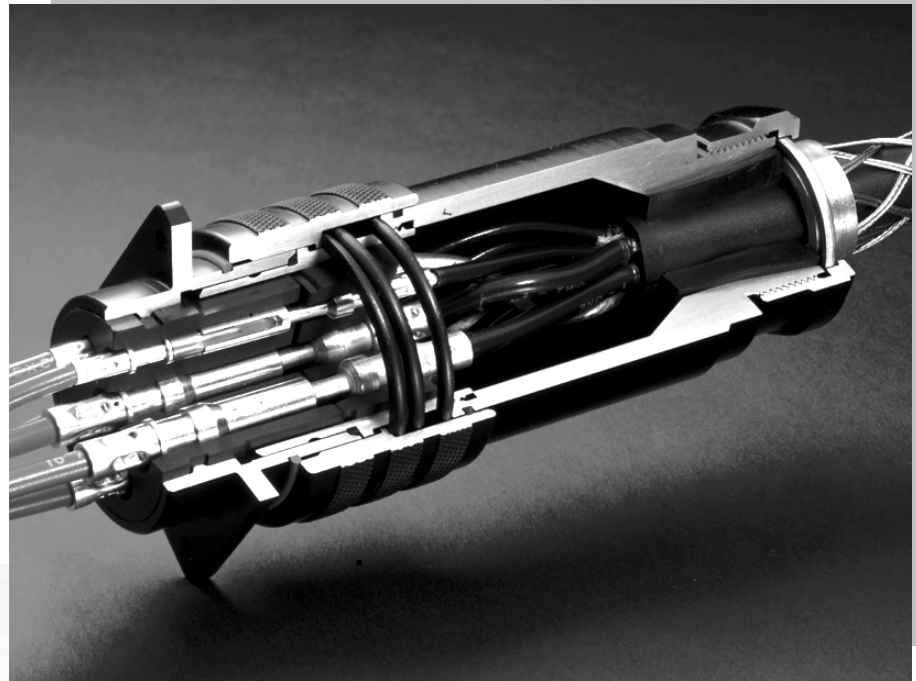

Insert Configuration

2 Contacts

16 - 11
2 - #12
Serv. A

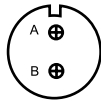

16 - 13
2 - #12
Serv. A

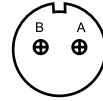

18 - 3
2 - #12
Serv. D

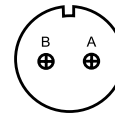

20 - 23
2 - #8
Serv. A

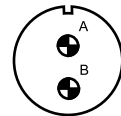

22 - 1
2 - #8
Serv. D

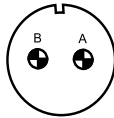

22 - 8
2 - #12
Serv. E

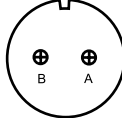

22-11*
2-#16
Serv. B

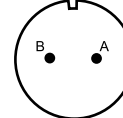

24 - 9
2 - #4
Serv. A

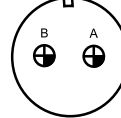

3 Contacts

16 - 7
1 - #8
2 - #16
Serv. A

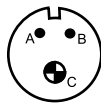

16 - 10
3 - #12
Serv. A

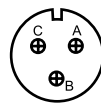

18 - 5
2 - #12
1 - #16
Serv. D

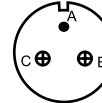

18 - 22
3 - #16
Serv. D
20 - 4

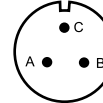

20 - 3
3 - #12
Serv. D

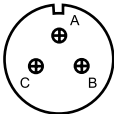

20 - 6
3 - #16
Serv. D

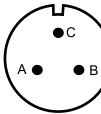

20 - 19
3 - #8
Serv. A

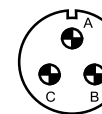

22 - 2
3 - #8
Serv. D

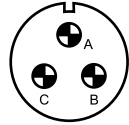

22 - 9
3 - #12
Serv. E

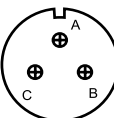

28 - 3
3 - #8
Serv. E

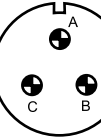

28 - 6
3 - #4
Serv. D

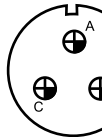

4 Contacts

16 - 9
2 - #12
2 - #16
Serv. A

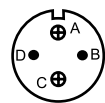

18 - 4
4 - #16
Serv. D

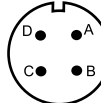

18 - 10
4 - #12
Serv. A

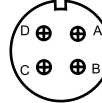

18 - 13
3 - #12
1 - #8
Serv. A

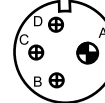

Contact Legend

NOTE: All illustrations are front view pin insert.



#16

#12

#8

#4

*consult factory.

Dust Caps are available for plug and receptacles please contact factory for more detail.

Insert Configurations

4 Contacts

20 - 4
4 - #12
Serv. D

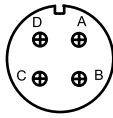

20 - 24
2 - #8
2 - #16
Serv. A

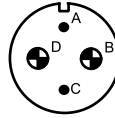

22 - 4
2 - #8
2 - #12
Serv. A

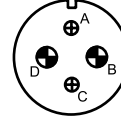

22 - 10
4 - #16
Serv. E

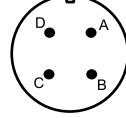

22 - 22
4 - #8
Serv. A

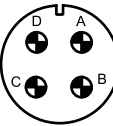

24 - 22
4 - #8
Serv. D

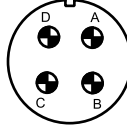

5 Contacts

18 - 11
5 - #12
Serv. A

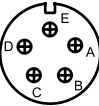

18 - 20
5 - #16
Serv. A

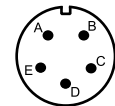

18 - 29
5 - #16
Serv. A

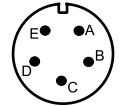

20 - 14
3 - #12
2 - #8
Serv. A

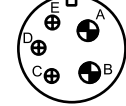

22 - 12
2 - #8
3 - #16
Serv. A

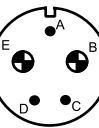

22 - 13
1 - #16
4 - #12
Serv. A

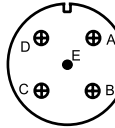

22 - 34
3 - #12
2 - #16
Serv. D

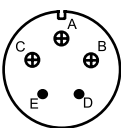

24 - 12
2 - #4
3 - #12
Serv. A

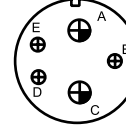

28 - 5
1 - #12
2 - #4
2 - #16
Serv. D

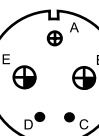

6 Contacts

18 - 12
6 - #16
Serv. A

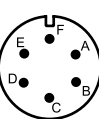

20 - 8
4 - #16
2 - #8
Inst.

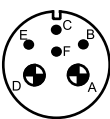

20 - 17
5 - #12
1 - #16
Serv. A

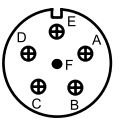

20 - 22
3 - #8
3 - #16
Serv. A

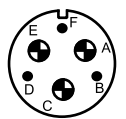

22 - 5
2 - #12
4 - #16
Serv. A

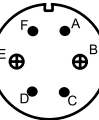

22 - 15
5 - #12
1 - #16
Serv. D

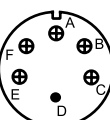

Contact Legend

NOTE: All illustrations are front view pin insert.



#16

#12

#8

#4

*consult factory.

Dust Caps are available for plug and receptacles please contact factory for more detail.

7 Contacts

18 - 9
5 - #16
2 - #12
Serv. INST

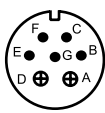

20 - 15
7 - #12
Serv. A

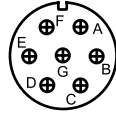

22 - 28
7 - #12
Serv. A

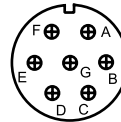

24 - 2
7 - #12
Serv. D

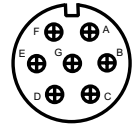

24 - 10
7 - #8
Serv. A

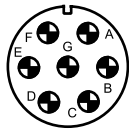

24 - 16
3 - #16
1 - #8
3 - #12
Serv. A

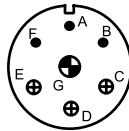

24 - 27
7 - #16
Serv. A

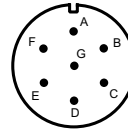

28 - 10*
3 - #12
2 - #8
2 - #4
Serv. A

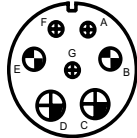

8 Contacts

18 - 8
1 - #12
7 - #16
Serv. A

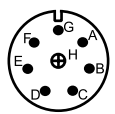

20 - 7
8 - #16
Serv. A

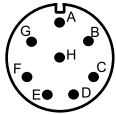

22 - 18
8 - #16
Serv. A

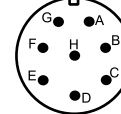

22 - 23
8 - #12
Serv. A

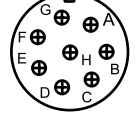

24 - 6
8 - #12
Serv. A

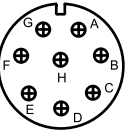

9 Contacts

20 - 16*
7 - #16
2 - #12
Serv. A

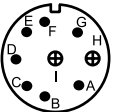

20 - 18*
3 - #12
6 - #16
Serv. A

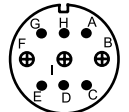

20 - 21*
1 - #12
8 - #16
Serv. A

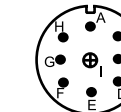

22 - 16*
3 - #12
6 - #16
Serv. A

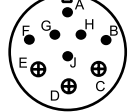

22-20*
9 - #16
Serv. A

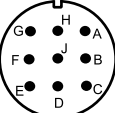

22 - 27*
1 - #8
8 - #16
Serv. A

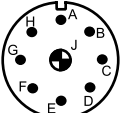

24 - 11*
3 - #8
6 - #12
Serv. A

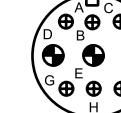

9 Contacts

28 - 1
3 - #8
6 - #12
Serv. A

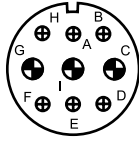

10 Contacts

18 - 1
10 - #16
Serv. A

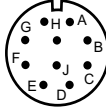

18 - 19
10 - #16
Serv. A

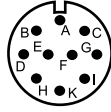

24 - 21
1 - #8
9 - #16
Serv. D

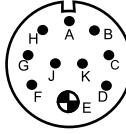

28 - 19
4 - #12
6 - #16
Serv. A

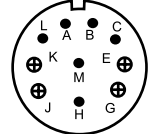

11 Contacts

20 - 33
11 - #16
Serv. A

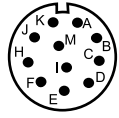

24 - 20
2 - #12
9 - #16
Serv. D

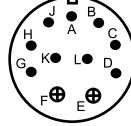

12 Contacts

28 - 8
2 - #12
10 - #16
Serv. A

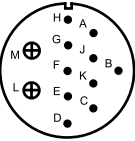

28 - 9
6 - #12
6 - #16
Serv. D

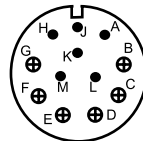

28 - 18
12 - #16
Serv. A

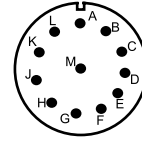

13 Contacts

20 - 11
13 - #16
Serv. INST

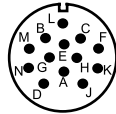

Insert Configuration

14 Contacts

20 - 27
14 - #16
Serv. A

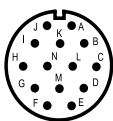

22 - 19
14 - #16
Serv. A

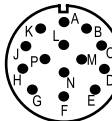

28 - 2
2 - #12
12 - #16
Serv. D

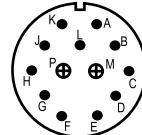

28 - 20
10 - #12
4 - #16
Serv. A

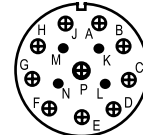

15 Contacts

28 - 17
15 - #16
Serv. A

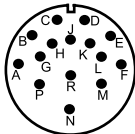

16 Contacts

24 - 5
16 - #16
Serv. A

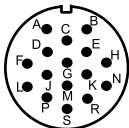

24 - 7
2 - #12
14 - #16
Serv. A

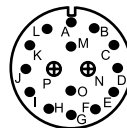

17 Contacts

20 - 29
17 - #16
Serv. A

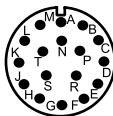

22 Contacts

28 - 11*
4 - #12
18 - #16
Serv. A

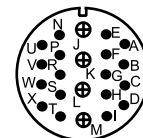

19 Contacts

22 - 14
19 - #16
Serv. A

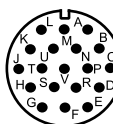

24 Contacts

24 - 28*
24 - #16
Serv. Inst

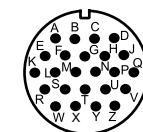

20 Contacts

28 - 16
20 - #16
Serv. A

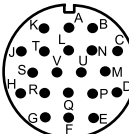

26 Contacts

28 - 12*
26 - #16
Serv. A

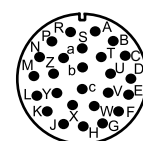

Contact Legend

NOTE: All illustrations are front view pin insert.



#16

#12

#8

#4

*consult factory.

Dust Caps are available for plug and receptacles please contact factory for more detail.

Engineering Data Performance Specifications

Contact Data

1. Contact (only) - Non-interrupting maximum continuous rating amperes.
2. Multi-circuit - non-interrupting maximum continuous current rating amperes.
3. Millivolt drop measurement made at opposite ends of mated contacts - pin and socket.
4. Based on crimp contact wire barrel dimensions.
5. Crimp wire barrel depth defines insulated wire strip length.
6. Range of wire AWG that can be crimped to given contact size.

Service Rating		
Service Rating	Operating Voltage DC at Sea Level	Operating Voltage AC at Sea Level
Inst.	250V	200V
A	700V	500V
D	1250V	900V
E	1750V	1250V
B	2450V	1750V
C	4200V	3000V

Contact Size AWG	Contact (Only) Amps	Multi Circuit Amps	M.V. Drop	Max. Wire AWG Dia. Inches (mm)*	Wire Barrel Depth Inches (mm)*	Wire AWG Range
Notes -	1	2	3	4	5	6
16	22	13	21	.056(1.4)	.25(6.35)	16, 18, 20
12	41	23	20	.090(2.27)	.33(8.5)	12, 14
8	73	46	12	.174(4.42)	.48(12.2)	8
4	135	80	10	.257(6.53)	.48(12.2)	4

* All metric dimension conversions are rounded.

Performance Data

The P-Lok connector series is designed to be a quick release version of MIL-C-5015 and maintains the same characteristics, sizes and insert arrangements. However, it is not mateable to MIL-C-5015 connectors. P-lok is environmentally resistant and meets IP65 requirements for coupled connectors. Designed for vibration, rapid mating and low profile applications. Available with either solder or crimp contacts.

NOTE: Connectors should not be mated and unmated under electrical load.

Operating Temperature Rating	-67° F (-55° C) to 257° F (125° C). The combination of ambient temperatures and current loading of contacts must not produce an insert temperature in excess of 257° F (125° C).
Corrosion Resistance	48 hours, method 1001 of MIL-STD-1344 No exposure of base metal.
Fluid Resistance	Resistant to most oils, acids and alkalis (other fluids can be tested on request).
Humidity & Moisture Resistance	Class E meets IP65 requirements for coupled connectors.
Air Leakage	Meets MIL-C-5015 for class E specification requirement of one cubic inch/hour maximum.
Vibration	Designed to resist severe vibration.
Durability	Meets MIL-C-5015 standard for coupling and uncoupling 100 times under normal operative service.



- Recognized under Underwriters Laboratories, Inc. File No. E109316 for 250 volts
- Certified by Canadian Standards Association File No. LR83458

P-Lok Part Numbering Guide

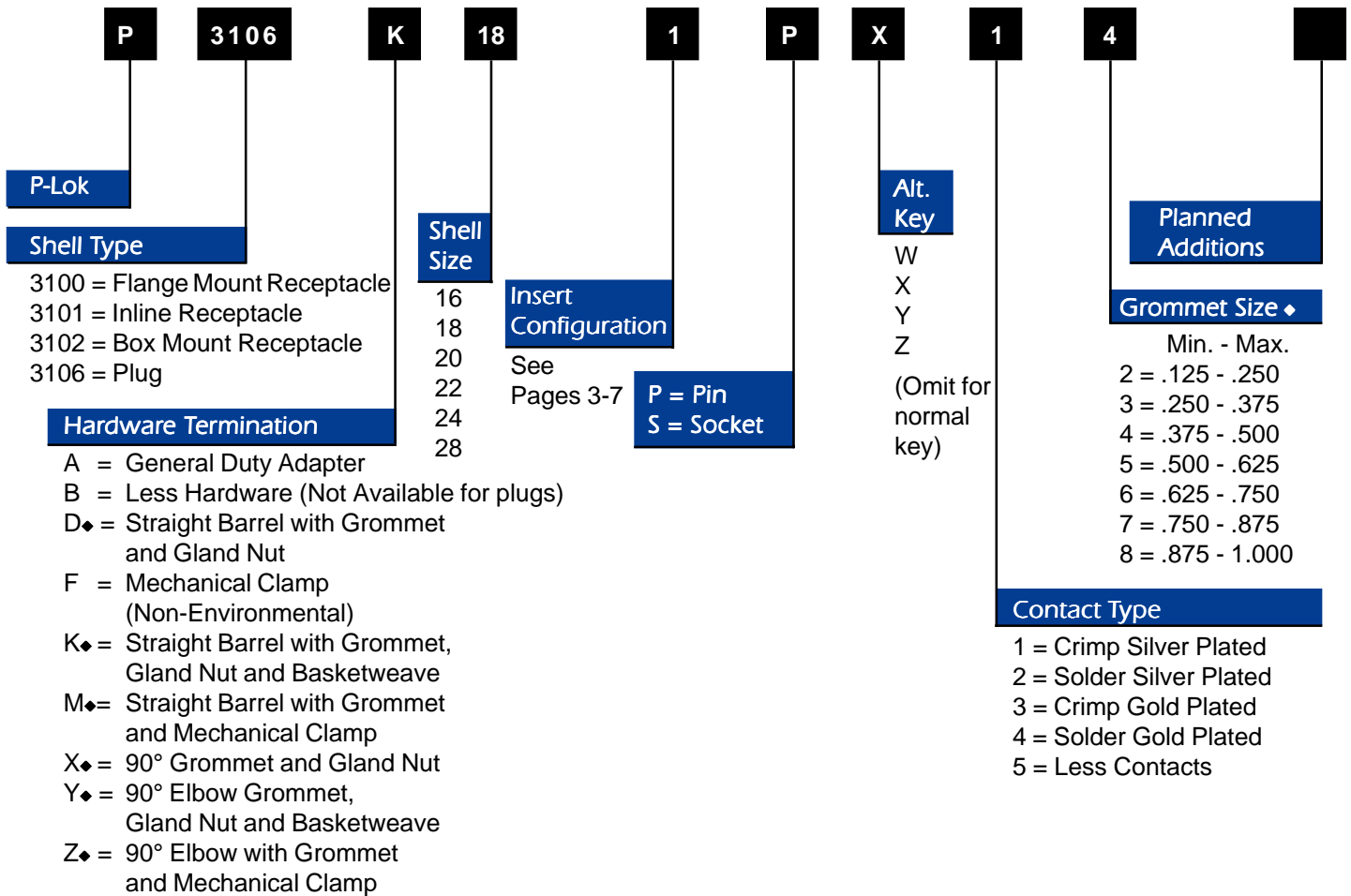

♦ Must include grommet size to complete part Number.

Shell Size	♦ Grommet Entry Size						
	2	3	4	5	6	7	8
16	X	X	X				
18	X	X	X	X			
20	X	X	X	X	X		
22	X	X	X	X	X	X	X
24	X	X	X	X	X	X	X
28	X	X	X	X	X	X	X

(F, M, Z) Mechanical Clamp Entry Size	
16	.400 - .550
18	.400 - .600
20	.500 - .775
22	.500 - .775
24	.600 - .950
28	.600 - .950

* NOTE - Dust caps are available for plug and receptacles. Please contact factory for more detail.

Dimensional Information

(Overall Clearance Dimensions)

NOTE 1: Insert configuration determines connector shell size. Refer to pages 3-7.
 NOTE 2: All dimensions shown are nominal. Consult factory for additional design specifications.
 NOTE 3: Dimensions: Inches (mm)

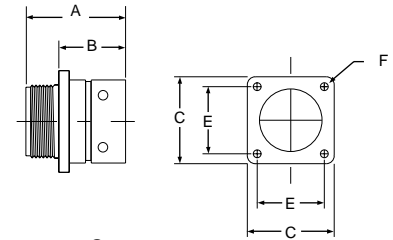

P3100B

Flange Mount Receptacle

(Note 1)	A	B	C	D	E	F	G
16	1.375(34.90)	0.898(22.81)	1.25(31.8)	N/A	0.968(24.59)	0.141(3.58)	N/A
18	1.375(34.90)	0.898(22.81)	1.38(35.1)	N/A	1.062(26.97)	0.141(3.58)	N/A
20	1.375(34.90)	0.898(22.81)	1.50(38.4)	N/A	1.156(29.36)	0.141(3.58)	N/A
22	1.375(34.90)	0.898(22.81)	1.63(41.4)	N/A	1.250(31.75)	0.141(3.58)	N/A
24	1.375(34.90)	0.898(22.81)	1.75(44.5)	N/A	1.375(34.93)	0.156(3.96)	N/A
28	1.375(34.90)	0.898(22.81)	2.00(50.8)	N/A	1.562(39.67)	0.156(3.96)	N/A

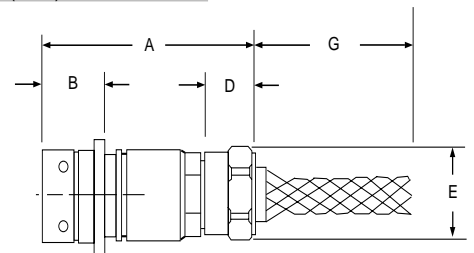

P3100D - P3100K

Flange Mount Receptacle w/wo Basketweave

(Note 1)	A	B	C	D	E	F	G
16	3.50(88.9)	0.898(22.81)	N/A	.810(20.57)	1.116(28.35)	NA	4.88(124.0)
18	3.50(88.9)	0.898(22.81)	N/A	.810(20.57)	1.249(31.72)	NA	5.50(139.7)
20	4.00(101.6)	0.898(22.81)	N/A	.810(20.57)	1.463(37.316)	NA	5.50(139.7)
22	4.00(101.6)	0.898(22.81)	N/A	.810(20.57)	1.463(37.16)	NA	5.50(139.7)
24	4.25(108.0)	0.898(22.81)	N/A	.810(20.57)	1.743(44.27)	NA	7.13(181.1)
28	4.92(125.0)	0.898(22.81)	N/A	1.194(30.33)	1.743(44.27)	NA	7.13(181.1)

P3100M

Flange Mount Receptacle w/ Mechanical Clamp

(Note 1)	A	B	C	D	E	F	G
16	3.63(92.13)	.898(22.81)	N/A	.937(23.80)	1.157(29.39)	NA	NA
18	3.63(92.13)	.898(22.81)	N/A	.937(23.80)	1.248(31.70)	NA	NA
20	4.13(104.83)	.898(22.81)	N/A	.937(23.80)	1.469(37.31)	NA	NA
22	4.13(104.83)	.898(22.81)	N/A	.937(23.80)	1.469(37.31)	NA	NA
24	4.38(111.18)	.898(22.81)	N/A	1.031(26.19)	1.689(42.90)	NA	NA
28	5.05(128.20)	.898(22.81)	N/A	1.031(26.19)	1.689(42.90)	NA	NA

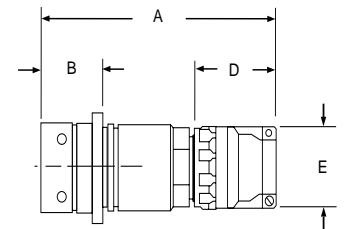

P3100X - P3100Y

90° Flange Mount Receptacle w/wo Basketweave

(Note 1)	A	B	C	D	E	F	G	Max Cable Dia
16	2.619(66.52)	.898(22.81)	N/A	0.810(20.57)	1.116(28.35)	2.24(56.8)	4.88(124.0)	0.500(11.10)
18	2.811(71.39)	.898(22.81)	N/A	0.810(20.57)	1.249(31.72)	2.32(58.9)	5.50(139.7)	0.625(15.88)
20	2.980(75.68)	.898(22.81)	N/A	0.810(20.57)	1.463(37.16)	2.48(63.0)	5.50(139.7)	0.750(19.05)
22	2.980(75.68)	.898(22.81)	N/A	0.810(20.57)	1.463(37.16)	2.62(66.6)	5.50(139.7)	0.750(19.05)
24	3.245(82.41)	.898(22.81)	N/A	0.810(20.57)	1.743(44.27)	2.93(74.3)	7.13(181.1)	1.000(25.40)
28	3.245(82.41)	.898(22.81)	N/A	1.194(30.33)	1.743(44.27)	3.22(81.8)	7.13(181.1)	1.000(25.40)

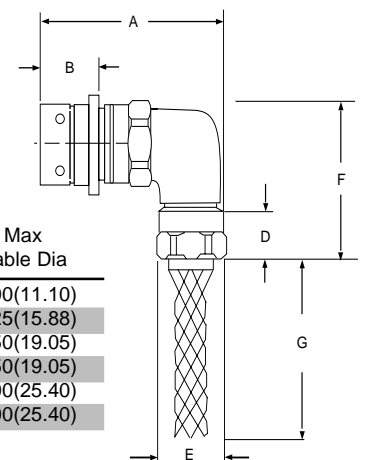

P3100Z

90° Flange Mount Receptacle w/ Mechanical Clamp

(Note 1)	A	B	C	D	E	F	Max Cable Dia
16	2.640(67.04)	.898(22.81)	N/A	.937(23.80)	1.157(29.39)	2.364(60.05)	.550(13.97)
18	2.810(71.37)	.898(22.81)	N/A	.937(23.80)	1.248(31.70)	2.447(62.15)	.600(15.24)
20	2.983(75.763)	.898(22.81)	N/A	.937(23.80)	1.469(37.31)	2.607(66.22)	.750(19.69)
22	2.983(75.76)	.898(22.81)	N/A	.937(23.80)	1.469(37.31)	2.750(69.85)	.750(19.69)
24	3.218(81.72)	.898(22.81)	N/A	1.031(26.19)	1.689(42.90)	3.052(77.52)	.950(24.13)
28	3.218(81.72)	.898(22.81)	N/A	1.031(26.19)	1.689(42.90)	3.347(85.01)	.950(24.13)

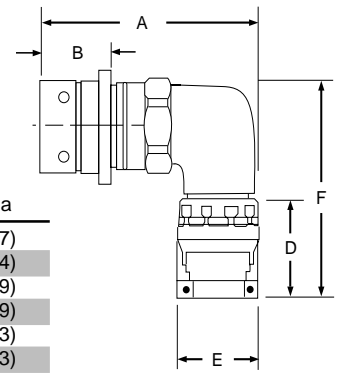

P3101D - P3101K

In-Line Receptacle w/wo Basketweave

(Note 1)	A	B	C	D	E	F	G
16	3.50(88.9)	NA	1.214(30.84)	.810(20.57)	1.116(28.35)	NA	4.88(124.0)
18	3.50(88.9)	NA	1.380(35.05)	.810(20.57)	1.249(31.72)	NA	5.50(139.7)
20	4.00(101.6)	NA	1.450(36.83)	.810(20.57)	1.463(37.316)	NA	5.50(139.7)
22	4.00(101.6)	NA	1.612(40.94)	.810(20.57)	1.463(37.16)	NA	5.50(139.7)
24	4.25(108.0)	NA	1.750(44.45)	.810(20.57)	1.743(44.27)	NA	7.13(181.1)
28	4.92(125.0)	NA	2.000(50.80)	1.194(30.33)	1.743(44.27)	NA	7.13(181.1)

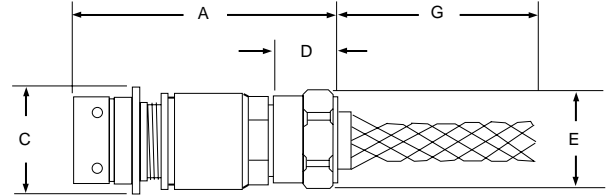

P3101M

In-Line Receptacle w/ Mechanical Clamp

(Note 1)	A	B	C	D	E	F	G
16	3.63(92.13)	NA	1.214(30.84)	.937(23.80)	1.157(29.39)	NA	NA
18	3.63(92.13)	NA	1.380(35.05)	.937(23.80)	1.248(31.70)	NA	NA
20	4.13(104.83)	NA	1.450(36.83)	.937(23.80)	1.469(37.31)	NA	NA
22	4.13(104.83)	NA	1.612(40.94)	.937(23.80)	1.469(37.31)	NA	NA
24	4.38(111.18)	NA	1.750(44.45)	1.031(26.19)	1.689(42.90)	NA	NA
28	5.05(128.20)	NA	2.000(50.80)	1.031(26.19)	1.689(42.90)	NA	NA

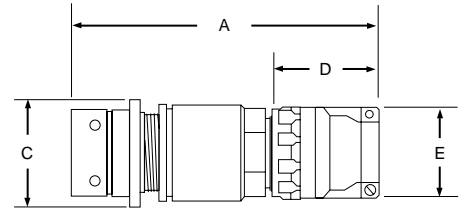

P3101X - P3101Y

90° In-Line Receptacle w/wo Basketweave

(Note 1)	A	B	C	D	E	F	G	Max Cable Dia
16	2.619(66.52)	NA	1.214(30.84)	0.810(20.57)	1.116(28.35)	2.24(56.8)	4.88(124.0)	.500(11.10)
18	2.811(71.39)	NA	1.380(35.05)	0.810(20.57)	1.249(31.72)	2.32(58.9)	5.50(139.7)	.625(15.88)
20	2.980(75.68)	NA	1.450(36.83)	0.810(20.57)	1.463(37.16)	2.48(63.0)	5.50(139.7)	.750(19.05)
22	2.980(75.68)	NA	1.612(40.94)	0.810(20.57)	1.463(37.16)	2.62(66.6)	5.50(139.7)	.750(19.05)
24	3.245(82.41)	NA	1.750(44.45)	0.810(20.57)	1.743(44.27)	2.93(74.3)	7.13(181.1)	1.000(25.40)
28	3.245(82.41)	NA	2.000(50.80)	1.194(30.33)	1.743(44.27)	3.22(81.8)	7.13(181.1)	1.000(25.40)

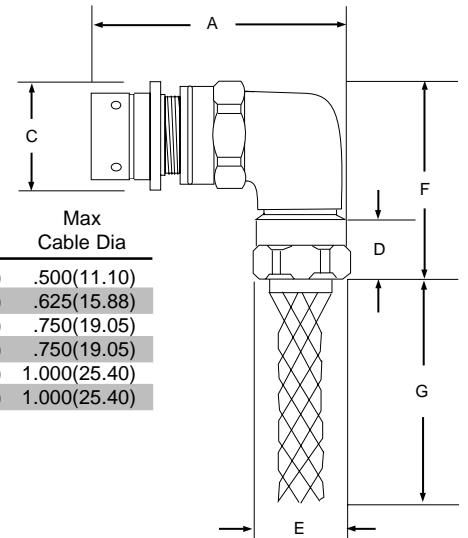

Dimensional Information

(Overall Clearance Dimensions)

NOTE 1: Insert configuration determines connector shell size. Refer to pages 3-7.

NOTE 2: All dimensions shown are nominal. Consult factory for additional design specifications.

NOTE 3: Dimensions: Inches (mm)

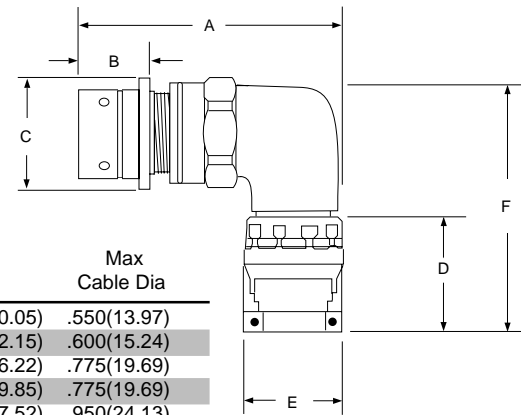

P3101Z

90° In-Line Receptacle w/ Mechanical Clamp

(Note 1)	A	B	C	D	E	F	Max Cable Dia
16	2.640(67.04)	.898(22.81)	1.214(30.84)	.937(23.80)	1.157(29.39)	2.364(60.05)	.550(13.97)
18	2.810(71.37)	.898(22.81)	1.380(35.05)	.937(23.80)	1.248(31.70)	2.447(62.15)	.600(15.24)
20	2.983(75.763)	.898(22.81)	1.450(36.83)	.937(23.80)	1.469(37.31)	2.607(66.22)	.775(19.69)
22	2.983(75.76)	.898(22.81)	1.612(40.94)	.937(23.80)	1.469(37.31)	2.750(69.85)	.775(19.69)
24	3.218(81.72)	.898(22.81)	1.750(44.45)	1.031(26.19)	1.689(42.90)	3.052(77.52)	.950(24.13)
28	3.218(81.72)	.898(22.81)	2.000(50.80)	1.031(26.19)	1.689(42.90)	3.347(85.01)	.950(24.13)

P3102B

Box Mount Receptacle

(Note 1)	A	B	C	D	E	F	G
16	1.375(34.9)	.898(22.81)	1.25(31.8)	N/A	0.968(24.59)	.141(3.58)	N/A
18	1.375(34.9)	.898(22.81)	1.38(35.1)	N/A	1.062(26.97)	.141(3.58)	N/A
20	1.375(34.9)	.898(22.81)	1.50(38.1)	N/A	1.156(29.36)	.141(3.58)	N/A
22	1.375(34.9)	.898(22.81)	1.63(41.4)	N/A	1.250(31.75)	.141(3.58)	N/A
24	1.375(34.9)	.898(22.81)	1.75(44.5)	N/A	1.375(34.93)	.156(3.96)	N/A
28	1.375(34.9)	.898(22.81)	2.00(50.8)	N/A	1.562(39.67)	.156(3.96)	N/A

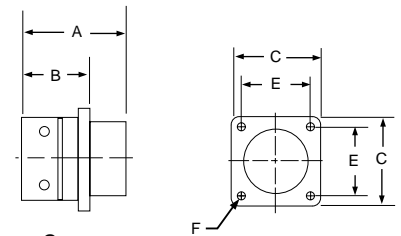

P3106D - P3106K

Plug w/wo Basketweave

(Note 1)	A	B	C	D	E	F	G
16	3.25(82.6)	1.605(40.77)	1.317(33.45)	.810(20.57)	1.116(28.35)	NA	4.88(124.0)
18	3.25(82.6)	1.605(40.77)	1.441(36.60)	.810(20.57)	1.249(31.72)	NA	5.50(139.7)
20	3.75(95.3)	1.605(40.77)	1.573(39.95)	.810(20.57)	1.463(37.16)	NA	5.50(139.7)
22	3.75(95.3)	1.605(40.77)	1.691(42.57)	.810(20.57)	1.463(34.93)	NA	5.50(139.7)
24	4.00(101.6)	1.605(40.77)	1.810(45.97)	.810(20.57)	1.743(44.27)	NA	7.13(181.1)
28	4.67(118.6)	1.605(40.77)	2.133(54.18)	1.194(30.33)	1.743(44.27)	NA	7.13(181.1)

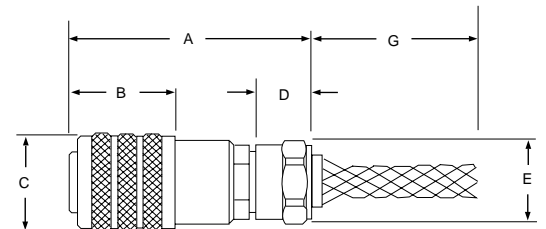

P3106M

Plug w/ Mechanical Clamp

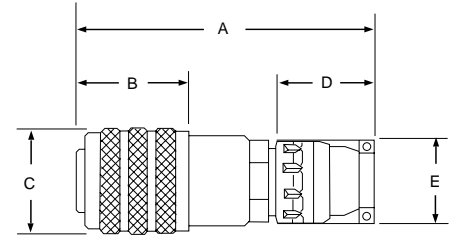

(Note 1)	A	B	C	D	E	F	G
16	3.98(101.1)	1.605(40.77)	1.317(33.45)	.937(23.80)	1.157(29.39)	NA	NA
18	3.98(101.1)	1.605(40.77)	1.441(36.60)	.937(23.80)	1.248(31.70)	NA	NA
20	4.48(113.8)	1.605(40.77)	1.573(39.95)	.937(23.80)	1.469(37.31)	NA	NA
22	4.48(113.8)	1.605(40.77)	1.691(42.95)	.937(23.80)	1.469(37.31)	NA	NA
24	4.82(122.4)	1.605(40.77)	1.810(45.97)	1.031(26.19)	1.689(42.90)	NA	NA
28	5.32(135.1)	1.605(40.77)	2.133(54.18)	1.031(26.19)	1.689(42.90)	NA	NA

P3106X, P3106Y

90° Plug w/wo Basketweave

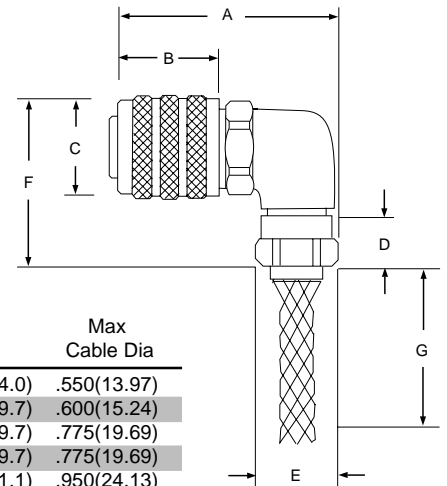

(Note 1)	A	B	C	D	E	F	G	Max Cable Dia
16	2.854(72.49)	1.605(40.77)	1.317(33.45)	.810(20.57)	1.106(28.09)	1.116(28.35)	4.88(124.0)	.550(13.97)
18	3.046(77.36)	1.605(40.77)	1.441(36.60)	.810(20.57)	1.239(31.47)	1.249(31.72)	5.50(139.7)	.600(15.24)
20	3.215(81.65)	1.605(40.77)	1.573(39.95)	.810(20.57)	1.453(36.91)	1.463(37.16)	5.50(139.7)	.775(19.69)
22	3.215(81.65)	1.605(40.77)	1.691(42.95)	.810(20.57)	1.453(36.91)	1.463(37.16)	5.50(139.7)	.775(19.69)
24	3.480(88.38)	1.605(40.77)	1.810(45.97)	.810(20.57)	1.733(44.02)	1.743(44.27)	7.13(181.1)	.950(24.13)
28	3.480(88.38)	1.605(40.77)	2.133(54.18)	1.194(30.33)	1.733(44.02)	1.743(44.27)	7.13(181.1)	.950(24.13)

P3106Z

90° Plug w/ Mechanical Clamp

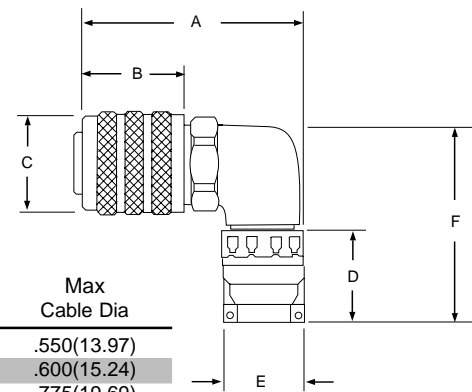

(Note 1)	A	B	C	D	E	F	Max Cable Dia
16	2.875(73.01)	1.605(40.77)	1.317(33.45)	.937(23.80)	1.157(29.39)	2.416(61.35)	.550(13.97)
18	3.045(77.34)	1.605(40.77)	1.441(36.60)	.937(23.80)	1.248(31.70)	2.478(62.93)	.600(15.24)
20	3.218(81.72)	1.605(40.77)	1.573(39.95)	.937(23.80)	1.469(37.31)	2.669(67.78)	.775(19.69)
22	3.218(81.72)	1.605(40.77)	1.691(42.95)	.937(23.80)	1.469(37.31)	2.790(70.85)	.775(19.69)
24	3.453(87.69)	1.605(40.77)	1.810(45.97)	1.031(26.19)	1.689(42.90)	3.082(78.28)	.950(24.13)
28	3.453(87.69)	1.605(40.77)	2.133(54.18)	1.031(26.19)	1.689(42.90)	3.414(86.70)	.950(24.13)

◆ Must include entry size to complete part number, refer to page 9.

Tools and Replacement Contacts

Insertion Tools

Contact Size	Tool Number
4	CP-5A04
8	CP-5A08
12	CP-5A12
16	CP-5A16



Extraction Tools

Contact Size	Tool Number
4	CP-5B04
8	CP-5B08
12	CP-5B12
16	CP-5B16



Hand Crimp Tools

Contact Size	Tool Number
12, 16	CP-5D10



Pneumatic Crimp Tools

Contact Size	Tool Number
12, 16	CP-5E12
8, 4	Consult Factory

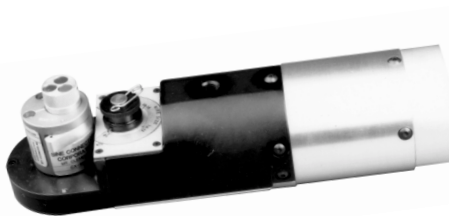

Replacement Contacts

Solder Size	Silver Plated	
	Pin No.	Socket No.
4	CP-3004-1N	CP-3104-1N
8	CP-3008-1N	CP-3108-1N
12	CP-3012-1N	CP-3112-1N
16	CP-3016-1N	CP-3116-1N

Solder Size	Gold Plated	
	Pin No.	Socket No.
4	CP-3004-1K	CP-3104-1K
8	CP-3008-1K	CP-3108-1K
12	CP-3012-1K	CP-3112-1K
16	CP-3016-1K	CP-3116-1K

Crimp Size	Silver Plated	
	Pin No.	Socket No.
4	CP-4004-1N	CP-4104-1N
8	CP-4008-1N	CP-4108-1N
12	CP-4012-1N	CP-4112-1N
16	CP-4016-1N	CP-4116-1N

Crimp Size	Gold Plated	
	Pin No.	Socket No.
4	CP-4004-1K	CP-4104-1K
8	CP-4008-1K	CP-4108-1K
12	CP-4012-1K	CP-4112-1K
16	CP-4016-1K	CP-4116-1K

Connector Assembly Instructions

FULLY READ AND UNDERSTAND THESE ASSEMBLY INSTRUCTIONS BEFORE BEGINNING ASSEMBLY.

Prepare cable by stripping jacket back squarely and to correct length, using appropriate wire strippers recommended by the cable manufacturer. When preparing the individual conductors in a cable or harnesses for assembly, make allowances in length for reaching the outermost circle of contacts cavities in the connector insert. The conductors need to be cut progressively longer as they extend out from the center of the cable or harness.

Before starting termination of the wires, it is necessary to layout the cable or harness in accordance with your wiring diagram. Proper

layout will reduce the need for twisting and crossing the conductors over each other. If the wiring layout is not correct, the termination operation will be difficult or even impossible and the chances of making an error will be greatly increased.

When using P-lok connectors with compression grommet seals. Use only the correct size compression grommets to assure a good seal around the cable jacket. Also make sure that the cable jacket is smooth where the grommet is to seal, remove any grooves or ridges if present by lightly sanding the outer cable jacket.

Use only the proper crimping, insertion and extraction tools.

Crimping contacts to the wire conductors must be done

carefully. First ensure that the wire jacket is stripped to the proper length, then ensure that the strands are all fully bottomed in the contact's well by using the sight hole on the contact before performing the crimp.

When using solder contacts, avoid direct contact of soldering tools to connector inserts. All solder terminations should meet ANSI/IPC-A-610 specifications.

Ensure that all contacts are the proper size before attempting to assemble them into the insert cavities. This point is particularly important when mixed contact sizes are used in the same connector.

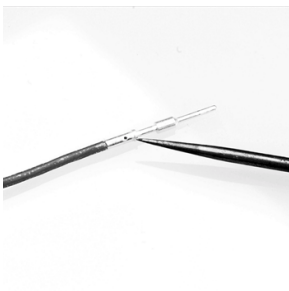

1. Insert stripped wire into contact pocket until it is visible through inspection hole.

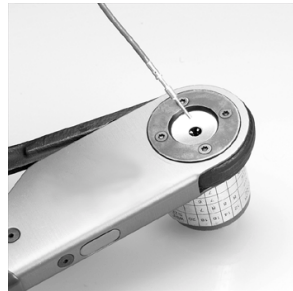

2. Fully seat contact in crimping tool.



3. Crimp contact onto wire in one full stroke. The ratchet on the crimping tool will not release until the tool has completed a full stroke.



4. Inspect crimp for wire visibility through inspection hole.



5. Use alcohol as a lubricant on contacts before insertion.



6. Secure connector in a smooth jaw vise and place contact in appropriate cavity of receptacle.



7. Use insertion tool to fully push contact into the receptacle insert.



8. A receptacle shell mounted in the vise creates a good way to hold a plug during contact insertion.

Connector Assembly

Instructions continued

Seat all contacts properly so that they will not be damaged or become disengaged during connector mating.

When inserts have more contact cavities than conductors used in the application, load all the cavities with either unused contacts or sealing plugs designed for this purpose. This will insure proper environmental sealing.

After all termination contacts have been inserted into the connector and inspected, the cable adapter and rear hardware should be

tightened with a wrench. This assembly operation should be done by placing the components in a vise with smooth faced jaws and tightened using a conventional wrench for components with hex surfaces or a strap wrench for circular components.

If for any reason terminated contacts have to be removed from a completed connector, be sure to remove the cable clamp and any other strain relief hardware before extracting the contacts. This will reduce the chance of damaging a contact or conductor.

When connectors having the same configuration and are mounted close together, alternate keying should be used to prevent mismatching or cross mating of connectors.

Never try to straighten bent contacts. Straightening bent contacts will result in a high resistance connection and expose the base metal to possible corrosion.

Always inspect all connector assemblies before putting connectors into operation.

Contact Size AWG	Contact (Only) Amps	Multi Circuit Amps	M.V. Multi	Max. Wire AWG Dia. Inches (mm)*	Wire Strip Length Inches (mm)*	Wire AWG Range
Notes -	1	2	3	4	5	6
16	22	13	21	.056(1.4)	.25(6.35)	16, 18, 20
12	41	23	20	.090(2.27)	.33(8.5)	12, 14
8	73	46	12	.174(4.42)	.48(12.2)	8
4	135	80	10	.257(6.53)	.48(12.2)	4

* All metric dimension conversions are rounded.



9. Place coupling ring then spring over plug shell before contact insertion.



10. Place all cable hardware on cable before contact insertion.



11. Place contact in appropriate cavity of plug. (properly lubricate - refer to step 5)

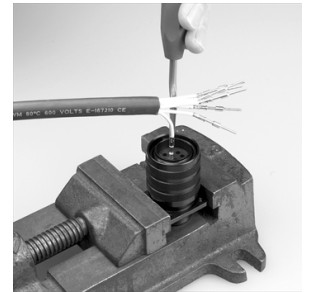

12. Use insertion tool to fully push the contact into the plug insert.

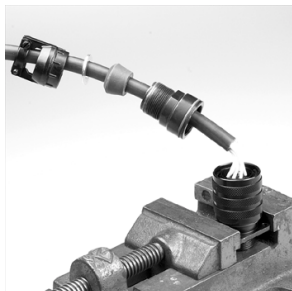

13. Plug with all contacts inserted, check that all contacts are fully seated.

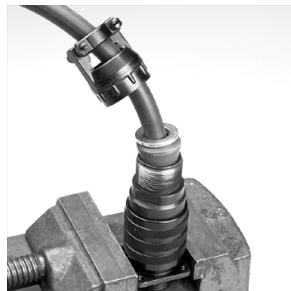

14. Secure cable hardware to the rear of the plug shell; ensure cable grommet is fully seated.



15. Ensure cable clamp is full threaded onto cable adapter.



16. Tighten cable clamp securely.



Swiftmate™ -

These connectors feature a robust construction and a unique push to mate / pull to unmate coupling system. They are a new member of the connector family and are compatible with connectors designed to MIL-C-5015 specifications.

Star-Line EX® is certified for use up to 1000V AC/DC in a Zone 1-IIC environment with IP65 rated sealing capabilities. This connector series offers solutions to harsh and potentially explosive environments.



Industria-Link™ is an industrial multi-connector cable assembly that is built to excel in a variety of industrial applications. Featuring vibration resistance, environmental sealing (IP65 rated) and resistance to most industrial fluids. Available in both static and continuous flexing cable versions, and offered in the most popular pin configurations and lengths.



A-Line® series, a low profile, quick mate, bayonet coupling system designed for commercial and industrial environments. Used in heavy-duty control and signal applications.

V-Line® series, a heavy-duty, multi-pin, metal shell, attachable electrical connector designed for commercial, industrial control and signal applications. One-piece five-keyed shell, coupling nut, cable adapter, gland and clamp nut are constructed of high-grade machined aluminum.

Star-Lok™, an extension of the Pyle National Star-Line series, is a heavy-duty, environmentally sealed plug engineered to resist vibration. The innovative option Star-Lok offers is a patented coupling mechanism. This mechanism allows a one-handed rapid engagement and release, providing a positive connection and consistent mating.



Star-Line® series is a heavy-duty, multi-pin, electrical connector designed for harsh environments. One-piece two-keyed shell, coupling nut, cable adapter, gland and clamp nut are constructed of high-grade machined aluminum with a hard coat finish for superior corrosion resistance.



Amphenol Industrial

Sine Systems* Pyle Connectors Corporation

25325 Joy Boulevard - Mt. Clemens, Michigan 48046-2336
Tel: 810.465.3131 / Fax: 810.465.1216

650 Grand Avenue / Suite 304 & 305 - Elmhurst, Illinois 60126
Tel: 630.832.4600 / Fax: 630.782.0700

www.sineco.com / e-mail: info@sineco.com

Amphenol Corporation
World Headquarters
358 Hall Avenue
Wallingford, CT 06492-3555
Tel: 203.265.8900 / Fax: 203.265.8628
www.amphenol.com

Amphenol
Sine Systems* Pyle Connectors Corporation
25325 Joy Boulevard
Mt. Clemens, Michigan 48046-2336
Tel: 810.465.3131 / Fax: 810.465.1216
www.sineco.com

Amphenol
Sine Systems* Pyle Connectors Corporation
650 Grand Avenue/ Suite 304
Elmhurst, Illinois 60126
Tel: 630.832.4600 / Fax: 630.782.0700

Amphenol Aerospace Operations
40-60 Delaware Street
Sidney, New York 13838-1395
Tel: 607.563.5011 / Fax: 607.563.5157

Amphenol-Tuchel Electronics
6900 Haggerty Road / Suite 180 & 200
Canton, MI 48187
Tel: 734.451.6400 / Fax: 734.451.7197

Amphenol Corporation -
Fiber Optic Products
1925A Ohio Street
Lisle, IL 60532
Tel: 630.960.1010 / Fax: 630.810.5640

Amphenol Corporation -
Spectra-Strip
720 Sherman Avenue
Hamden, CT 06514
Tel: 203.281.3200 / Fax: 203.281.5872
www.spectrastrip.amphenol.com

Amphenol Interconnect
Products Corporation
20 Valley Street
Endicott, NY 13760
Tel: 607.754.4444 / Fax: 607.786.4311
www.amphenol-aipc.com

Amphenol Corporation -
Communication and
Network Products Division
One Kennedy Avenue
Danbury, CT 06810
Tel: 203.743.9272 / Fax: 203.796.2004

Amphenol Corporation -
Severna Operations
3 Eastmans Road
Parsippany, NJ 07054
Tel: 973.503.1600 / Fax: 973.503.1704

Times Fiber Communications, Inc.
358 Hall Avenue
Wallingford, CT 06492
Tel: 203.265.8500 / Fax: 203.265.8422
www.timesfiber.com/tfchtm.html

TFC P & L Center
550 Research Parkway
Meriden, CT 06450
Tel: 203.634.4730 / Fax: 203.237.1380

Amphenol Canada Corporation
20 Melford Drive
Scarborough, Ontario
M1B 2X6
CANADA
Tel: 416.291.4401 / Fax: 416.292.0647

Times Fiber Communications, Inc.
The Edward Building
3400 East Prentice Ave., Suite 550
Englewood, Colorado 80111
Tel: 303-793-3500 / Fax: 303.793.3016

Times Fiber Communications, Inc.
380 Tightsqueeze Ind. Road
Chatham VA 24531
Tel: 804.432.1800 / Fax: 804.432.1836

Times Fiber Canada, Limited
O'Brien Road
P.O. Box 430
Renfrew, Ontario
Canada K7V 4A6
Tel: 613.432.8566 / Fax: 613.432.9373

Technical Products International Ltd.
2110 Notre Dame Avenue
Winnipeg, Mb
R3H 0K1 Canada
Tel: 204.697.2222 / Fax: 204.694.6164

Amphenol do Brasil LTDA
Morumbi Tower
Avenida Roque Petroni Junior 999 - 13th Floor
CEP 04707-910 Sao Paulo - SP
Brazil
Tel: 55 11 5185 2881 / Fax: 55 11 5185 2812

Mexico Sales Office
HQ Business center
Presidente Masaryk 61, Piso 2
CP 11560 Mexico D.F.,
Mexico
Tel: 525.254.7283 / Fax: 525.531.9659

Amphenol Benelux BV
Central Office:
Hoofdveste 19
3992 DH Houten
The Neatherlands
Tel: 31.30.6358015 / Fax: 31.30.6377899
e-mail: s.verwijs@amphenol-nl.com

Amphenol Poland
18 Niedumego Street
41-600 Swietochlowice
Katowice, Poland
Tel: 48.322.453634 / Fax: 48.322.421364
e-mail: info@amphenol-at.com

Amphenol Scandinavia
Box 2047 S-194 02 Upplands Väsby
Johanneslundsvägen 2
19461 Upplands Väsby
Sweden
Tel: +46 (0) 8 594 104 40 / Fax: +46 (0) 8 590 33 8 00
e-mail: info@amphenol-se.com

Amphenol Gesellschaft mbH
Swiss Office
Route du Roule 41
CH-1723 Marly, Switzerland
Tel: +41 26 4363818 / Fax: +41 26 4300177
e-mail: info@amphenol-nl.com

Amphenol Gesellschaft mbH
Johnstrasse 42, 2.Stock, Top 3A
1150 Wien
Austria
Tel: 43.1.985.15 11 / Fax: 43.1.982.61 01
e-mail: info@amphenol-at.com

Amphenol Italia S.p.A.
Galleria Gandhi, 2-27
20017 Mazzo di Rho
Milano, Italy
Tel: +39 2 939 04192 / Fax: +39 2 939 01030
e-mail: ftognoli@amphenol-it.com

Amphenol Socapex S.A.S.
Promenade de l'Arve
BP 29
Thyez 74301 Cluses Cedex
France
Tel: 33 4 5089 2800 / Fax: 33 4 5096 2975

Amphenol Tuchel Electronics GmbH
August-Haessler-Strasse 10
74080 Heilbronn
Germany
Tel: 49.7131.929.0 / Fax: 49.7131.929.414

Amphenol Australia Ltd.
248 Wickham Road, Moorabbin
Victoria 3189, Melbourne
Australia
Tel: 61.3.9555.1566 / Fax: 61.3.9553.3801

Amphenol East Asia Limited
Units 3-12, 10/F & the 11/F
Wah Luen Industrial Centre
15-21 Wong Chuk Yeung Street
Fotan, Shatin, N.T., Hong Kong
Tel: 852.2699.2663
Fax: 852.2691.1774 (General)
852.2688.0974 (Sales)

Amphenol East Asia Limited
13 Floor 1310
Samho Mulsan Bldg., B-dong
Yang Jae-dong 275-6
Seo Cho-ku
Seoul, Korea
Tel: 82.2.785.1588
Fax: 82.2.785.1589

Amphetronix Limited
Plot No. 105
Bhosari Industrial Area
Post Box No. 1
Pune 411 026
India
Tel: 91.212.790363 / Fax: 91.212.790581
Telex: 953.0146.237
AMFETRONIX

Amphenol Limited
Thanet Way, Whitstable
Kent CT5 3JF
Great Britain
Tel: 44.1227.773.200 / Fax: 44.1227.276.571

Amphenol Limited
Romsey Industrial Estate
Greatbridge Road
Romsey, Hampshire SO5 0HR
Great Britain
Tel: 44.1794.517.575 / Fax: 44.1794.516.246

Pyle-National Limited
100 Sherbrook Road
Daybrook Nottingham
Great Britain NG5 6AT
Tel: 44.1159.208.116 / Fax: 44.1159-208-896

Times Fiber Communications, Inc.
Gainsborough house
Sheering Lower Road
Sawbridgeworth
Hertfordshire CM21 9RG
Great Britain
Tel: 44.1279.600.676 / Fax: 44.1279.600.677

Amphenol Limited
Unit 29, Lynedoch St. Industrial Estate
Greenock
Scotland PA15 4AY
Tel: 44.1475.888.898 / Fax: 44.1475.729.109

Amphenol Japan, K.K.
2-3-27, Kudan Minami
Chiyoda-ku, Toyoko 102
Japan
Tel: 81 3 3263 5611 / Fax: 81 3 5276 7059



This publication must not be used in any form or manner without prior approval in writing (copyright law, fair trading law, civil code). We reserve the right to modify designs in order to improve quality, keep pace with technological advancement or to meet particular requirements in production. Specifications subject to change.

FSMP0327.06.00