

# CRIMP RING ADAPTOR

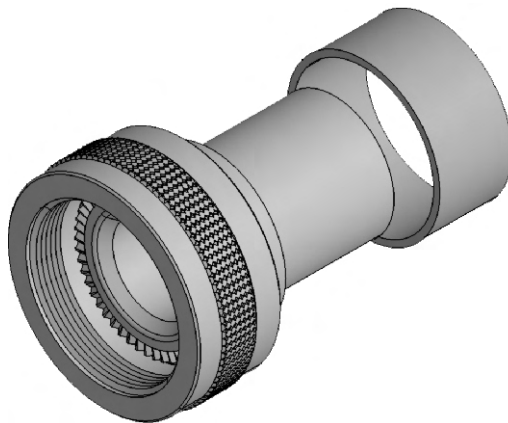

Many cable terminations where heat shrink boots are used will require provision for terminating the screens too. It is achieved in this type of back shell through a ring, which can be crimped to the back shell body holding the screens in between.

For Connector Group		Page No.
J	→	VI-1 - VI-2
K	→	VI-3 - VI-4
L	→	VI-5 - VI-6
M	→	VI-7 - VI-8
N	→	VI-9 - VI-10

**Note:** For Connector group Identification refer Table 1 - A, B, C, D (Page 7-11) and for Material / Plating Finish, Refer Table-2 (Page 12)



Connector Group - J

Straight, 90°, 45°

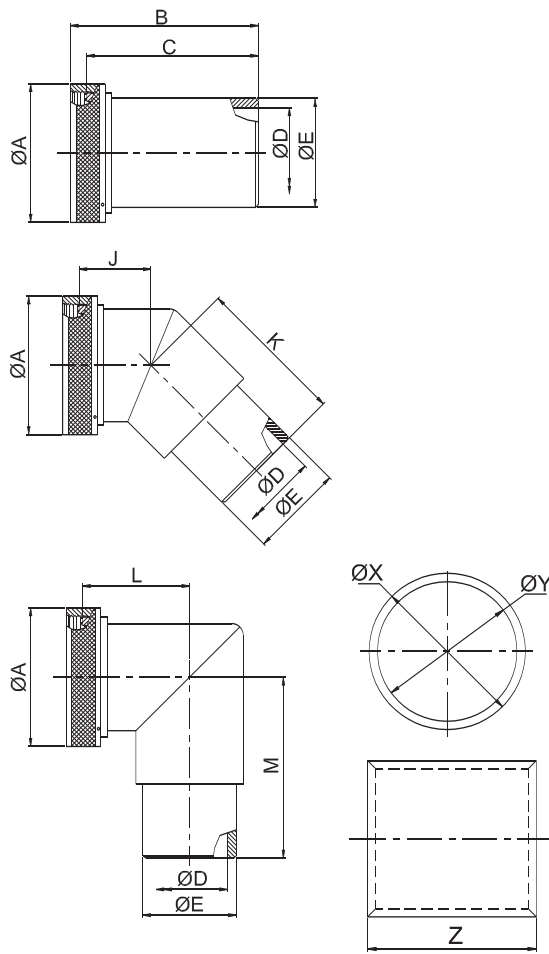

### Amphenol Part Number

BC1 X X J 99 99 9 X X

- Series
  - BC1: Adaptor with ring
  - BC2: Adaptor
  - BC3: Ring
- Angle
  - S: straight
  - A: 90deg
  - B: 45deg
  - X: For BC3
- Coupling
  - R: spin
  - S: Self lock
  - X: For BC3
- Finish: see Table-2 (for BC1&BC2)  
X :For BC3
- Constant: X
- Length
  - 9 - for standard
  - Length in table / figure
- Entry Size
  - 99 - for standard
  - Entry Size in table / figure
- Shell size
  - See Table-A (for BC1&BC2)
  - Table-B (for BC3)
- Connector group
  - X: For BC3

### MIL Part Number

M85049 / 99-9 -9 X

- MIL Series
- Slash sheet
  - 26: Straight, spin couplig
- Finish: See Table-2  
Omit for '26-2'
- Dash Number: See Table-A (for 26-1&26-3)  
Table-B(for 26-2)
- Crimp ring
  - 1 : Adaptor
  - 2 : Crimp ring
  - 3 : Adaptor with crimp ring

**NOTE:** \* For more cable entry and length options, contact factory

		TABLE - A															
AMPHENOL PART NUMBER DESIGNATOR	MIL PART NUMBER DESIGNATOR	CONNECTOR SHELL SIZE	A DIA. (MAX)		B (MAX)		C (MAX)		D DIA. (MAX)		E DIA. (MAX)		J (MAX)		K (MAX)		
			INCH	MM	INCH	MM	INCH	MM	INCH	MM	INCH	MM	INCH	MM	INCH	MM	
08	08	8	0.62	15.67	1.28	32.44	0.96	24.38	0.25	6.35	0.35	8.81	0.64	16.23	0.70	17.83	
10	10	10	0.73	18.64	1.28	32.44	0.96	24.38	0.33	8.26	0.50	12.70	0.66	16.87	0.73	18.59	
12	12	7/12	0.86	21.79	1.28	32.44	0.96	24.38	0.42	10.67	0.51	12.95	0.69	17.48	1.04	26.42	
14	14	12/14	0.98	24.99	1.28	32.44	0.96	24.38	0.54	13.72	0.63	16.00	0.71	17.91	1.07	27.18	
16	16	19/16	1.11	28.24	1.28	32.44	0.96	24.38	0.67	17.02	0.76	19.30	0.73	18.59	1.09	27.69	
18	18	27/18	1.22	30.94	1.28	32.44	0.96	24.38	0.79	20.04	0.89	22.61	0.75	19.00	1.10	27.94	
20	20	37/20	1.35	34.16	1.28	32.44	0.96	24.38	0.91	23.22	1.01	25.65	0.77	19.63	1.12	28.45	
22	22	22	1.47	37.29	1.28	32.44	0.96	24.38	1.04	26.39	1.13	28.70	0.80	20.32	1.16	29.46	
24	24	24	1.59	40.46	1.28	32.44	0.96	24.38	1.11	28.24	1.20	30.48	0.82	20.90	1.19	30.23	
28	28	28	1.97	50.01	1.44	36.55	0.96	24.38	1.39	35.28	1.56	39.62	-----	-----	-----	-----	
32	32	32	2.22	56.36	1.44	36.55	0.96	24.38	1.64	41.53	1.81	45.97	-----	-----	-----	-----	
36	36	36	2.47	62.71	1.44	36.55	0.96	24.38	1.85	46.99	2.06	52.32	-----	-----	-----	-----	
40	40	40	2.72	69.06	1.44	36.55	0.96	24.38	2.07	52.45	2.31	58.67	-----	-----	-----	-----	
44	44	44	2.97	75.41	1.44	36.55	0.96	24.38	2.32	58.93	2.56	65.02	-----	-----	-----	-----	
48	48	48	3.22	81.76	1.44	36.55	0.96	24.38	2.57	65.28	2.81	71.37	-----	-----	-----	-----	

Table Continued

AMPHENOL PART NUMBER DESIGNATOR	MIL PART NUMBER DESIGNATOR	CONNECTOR SHELL SIZE SIZE	L (MAX)		M (MAX)	
			INCH	MM	INCH	MM
08	08	8	0.75	19.05	0.81	20.62
10	10	10	0.81	20.62	0.88	22.23
12	12	7/12	0.88	22.23	1.22	30.99
14	14	12/14	0.92	23.37	1.29	32.77
16	16	19/16	0.98	24.89	1.35	34.29
18	18	27/18	1.02	25.91	1.37	34.80
20	20	37/20	1.08	27.43	1.43	36.32
22	22	22	1.14	28.96	1.51	38.35
24	24	24	1.20	30.48	1.58	40.13
28	28	28	-----	-----	-----	-----
32	32	32	-----	-----	-----	-----
36	36	36	-----	-----	-----	-----
40	40	40	-----	-----	-----	-----
44	44	44	-----	-----	-----	-----
48	48	48	-----	-----	-----	-----

AMPHENOL PART NUMBER DESIGNATOR	MIL PART NUMBER DESIGNATOR		CONNECTOR SHELL SIZE SIZE	X DIA.				Y DIA.				Z	
				MIN		MAX		MIN		MAX		INCH	MM
				INCH	MM	INCH	MM	INCH	MM	INCH	MM		
08	08	GREEN	8	0.45	11.38	0.46	11.63	0.40	10.16	0.41	10.41	0.25	6.35
10	10	RED	10	0.66	16.76	0.68	17.27	0.59	14.86	0.60	15.11	0.44	11.18
12	12	RED	7/12	0.66	16.76	0.68	17.27	0.59	14.86	0.60	15.11	0.44	11.18
14	14	BLUE	12/14	0.78	19.81	0.80	20.32	0.71	17.91	0.72	18.16	0.44	11.18
16	16	GRAY	19/16	0.91	23.11	0.93	23.62	0.84	21.21	0.85	21.46	0.44	11.18
18	18	BROWN	27/18	1.08	27.43	1.10	27.94	1.01	25.53	1.02	25.78	0.44	11.18
20	20	GREEN	37/20	1.20	30.48	1.22	30.99	1.13	28.58	1.14	28.83	0.44	11.18
22	22	PINK	22	1.32	33.53	1.34	34.04	1.25	31.62	1.26	31.88	0.44	11.18
24	24	YELLOW	24	1.39	35.23	1.41	35.74	1.31	33.32	1.32	33.58	0.44	11.18
28	28	RED	28	1.74	44.20	1.76	44.70	1.67	42.29	1.68	42.55	0.44	11.18
32	32	GRAY	32	1.99	50.55	2.01	51.05	1.92	48.64	1.93	48.90	0.44	11.18
36	36	GREEN	36	2.24	56.90	2.26	57.40	2.17	54.99	2.18	55.25	0.44	11.18
40	40	ORANGE	40	2.49	63.25	2.51	63.75	2.42	61.34	2.43	61.60	0.44	11.18
44	44	YELLOW	44	2.74	69.60	2.76	70.10	2.67	67.69	2.68	67.95	0.44	11.18
48	48	BLUE	48	2.99	75.95	3.01	76.45	2.92	74.04	2.93	74.30	0.44	11.18

**Note:** The material & finish for the crimp ring will always be as follows

Material: Copper as per ASTM B-75

Finish: Tin plating as per MIL-T-10727, Type-1

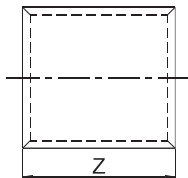
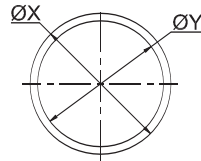
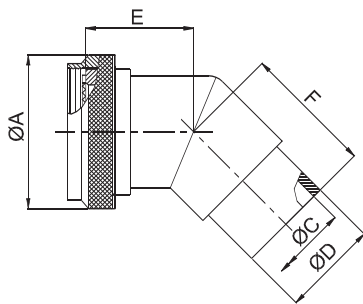
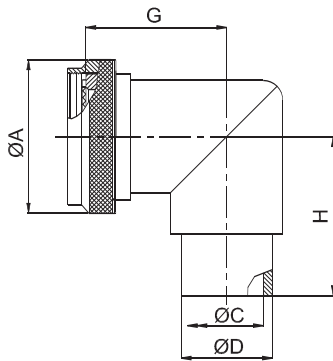
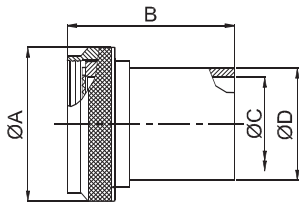

### Amphenol Part Number

BC1 X X K 99 99 9 X X

Series  
BC1: Adaptor with ring  
BC2: Adaptor  
BC3: Ring

Angle  
S: straight  
A: 90deg  
B: 45deg  
X: For BC3

Coupling  
R: spin  
S: Self lock  
X: For BC3

Finish: see Table-2  
(for BC1&BC2)  
X: For BC3

Constant: X

Length  
9 - for standard  
Length in table / figure

Entry Size  
99 - for standard  
Entry Size in table / figure

Shell size  
See Table-A  
(for BC1&BC2)  
Table-B (for BC3)

Connector group  
X: For BC3

### MIL Part Number

M85049 / 99-9 -9 X

MIL Series

Slash sheet  
33: Straight, spin couplig

Finish:  
See Table-2

Dash Number:  
See Table-A

Crimp ring  
2 :Adaptor without  
crimp ring

NOTE: \* For more cable entry and length options, contact factory

TABLE - A												
AMPHENOL PART NUMBER DESIGNATOR	MIL PART NUMBER DESIGNATOR	CONNECTOR SHELL SIZE SE - II / I	A DIA. ( MAX)		B (MAX)		C DIA. ( MAX)		D DIA. (MAX)		E ( MAX)	
			INCH	MM	INCH	MM	INCH	MM	INCH	MM	INCH	MM
08	08	8 / 9	0.75	19.05	1.14	28.96	0.27	6.86	0.35	8.89	0.64	16.23
10	10	10 / 11	0.85	21.59	1.14	28.96	0.34	8.64	0.50	12.70	0.66	16.87
12	12	12 / 13	1.00	25.40	1.14	28.96	0.44	11.18	0.51	12.95	0.69	17.48
14	14	14 / 15	1.10	27.94	1.14	28.96	0.56	14.22	0.63	16.00	0.71	17.91
16	16	16 / 17	1.25	31.75	1.14	28.96	0.69	17.53	0.76	19.30	0.73	18.59
18	18	18 / 19	1.40	35.56	1.14	28.96	0.80	20.32	0.89	22.61	0.75	19.00
20	20	20 / 21	1.50	38.10	1.14	28.96	0.93	23.62	1.01	25.65	0.77	19.63
22	22	22 / 23	1.65	41.91	1.14	28.96	1.05	26.67	1.13	28.70	0.80	20.32
24	24	24 / 25	1.75	44.45	1.14	28.96	1.13	28.70	1.20	30.48	0.82	20.90

Table Continued

AMPHENOL PART NUMBER DESIGNATOR	MIL PART NUMBER DESIGNATOR	CONNECTOR SHELL SIZE SE - II / I	F ( MAX)		G ( MAX)		H ( MAX)	
			INCH	MM	INCH	MM	INCH	MM
08	08	8 / 9	0.70	17.83	0.75	19.05	0.81	20.62
10	10	10 / 11	0.73	18.59	0.81	20.62	0.88	22.23
12	12	12 / 13	1.04	26.42	0.88	22.23	1.22	30.99
14	14	14 / 15	1.07	27.18	0.92	23.37	1.29	32.77
16	16	16 / 17	1.09	27.69	0.98	24.89	1.35	34.29
18	18	18 / 19	1.10	27.94	1.02	25.91	1.37	34.80
20	20	20 / 21	1.12	28.45	1.08	27.43	1.43	36.32
22	22	22 / 23	1.16	29.46	1.14	28.96	1.51	38.35
24	24	24 / 25	1.19	30.23	1.20	30.48	1.58	40.13

AMPHENOL PART NUMBER DESIGNATOR	MIL PART NUMBER DESIGNATOR		CONNECTOR SHELL SIZE SIZE	X DIA.				Y DIA.				Z	
				MIN		MAX		MIN		MAX		INCH	MM
				INCH	MM	INCH	MM	INCH	MM	INCH	MM		
08	08	GREEN	8	0.45	11.38	0.46	11.63	0.40	10.16	0.41	10.41	0.25	6.35
10	10	RED	10	0.66	16.76	0.68	17.27	0.59	14.86	0.60	15.11	0.44	11.18
12	12	RED	7/12	0.66	16.76	0.68	17.27	0.59	14.86	0.60	15.11	0.44	11.18
14	14	BLUE	12/14	0.78	19.81	0.80	20.32	0.71	17.91	0.72	18.16	0.44	11.18
16	16	GRAY	19/16	0.91	23.11	0.93	23.62	0.84	21.21	0.85	21.46	0.44	11.18
18	18	BROWN	27/18	1.08	27.43	1.10	27.94	1.01	25.53	1.02	25.78	0.44	11.18
20	20	GREEN	37/20	1.20	30.48	1.22	30.99	1.13	28.58	1.14	28.83	0.44	11.18
22	22	PINK	22	1.32	33.53	1.34	34.04	1.25	31.62	1.26	31.88	0.44	11.18
24	24	YELLOW	24	1.39	35.23	1.41	35.74	1.31	33.32	1.32	33.58	0.44	11.18
28	28	RED	28	1.74	44.20	1.76	44.70	1.67	42.29	1.68	42.55	0.44	11.18
32	32	GRAY	32	1.99	50.55	2.01	51.05	1.92	48.64	1.93	48.90	0.44	11.18
36	36	GREEN	36	2.24	56.90	2.26	57.40	2.17	54.99	2.18	55.25	0.44	11.18
40	40	ORANGE	40	2.49	63.25	2.51	63.75	2.42	61.34	2.43	61.60	0.44	11.18
44	44	YELLOW	44	2.74	69.60	2.76	70.10	2.67	67.69	2.68	67.95	0.44	11.18
48	48	BLUE	48	2.99	75.95	3.01	76.45	2.92	74.04	2.93	74.30	0.44	11.18

**Note:** The material & finish for the crimp ring will always be as follows

Material: Copper as per ASTM B-75

Finish: Tin plating as per MIL-T-10727, Type-1

Connector Group - L

Straight, 90°, 45°

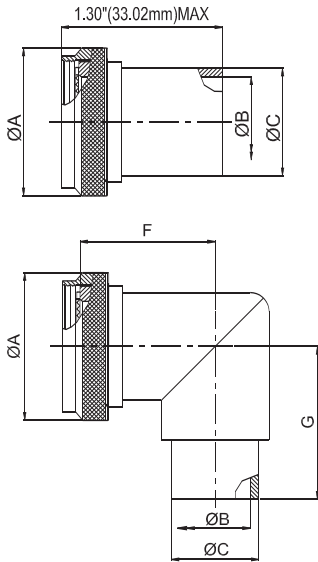

### Amphenol Part Number

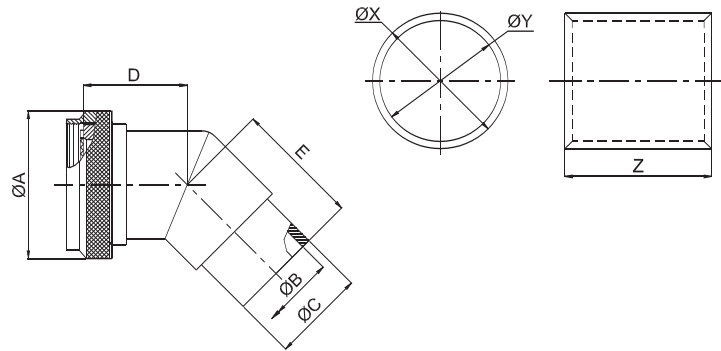
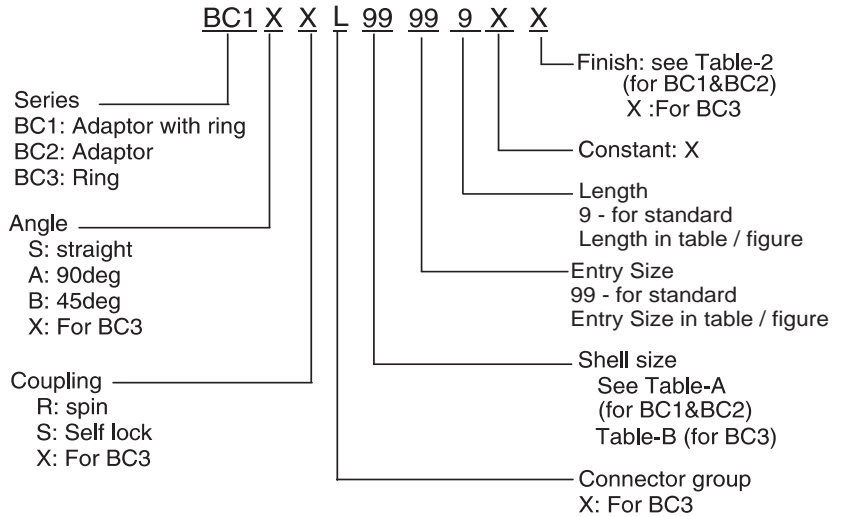

### MIL Part Number

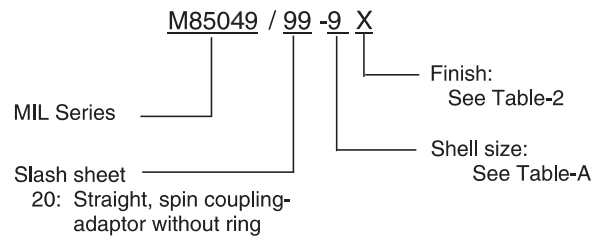

NOTE: \* For more cable entry and length options, contact factory

TABLE - A

AMPHENOL PART NUMBER DESIGNATOR	MIL PART NUMBER DESIGNATOR	CONNECTOR SHELL SIZE/CODE (REF.)	A DIA. (MAX)		B DIA. (MIN)		C DIA. (MAX)		D (MAX)		E (MAX)		F (MAX)		G (MAX)	
			INCH	MM	INCH	MM	INCH	MM	INCH	MM	INCH	MM	INCH	MM	INCH	MM
08	09	09 / A	0.75	19.05	0.27	6.73	0.35	8.81	0.64	16.23	0.70	17.83	0.75	19.05	0.81	20.62
10	11	11 / B	0.85	21.59	0.34	8.71	0.50	12.65	0.66	16.87	0.73	18.59	0.81	20.62	0.88	22.23
12	13	13 / C	1.00	25.40	0.44	11.10	0.51	12.95	0.69	17.48	1.04	26.42	0.88	22.23	1.22	30.99
14	15	15 / D	1.10	27.94	0.56	14.27	0.63	16.00	0.71	17.91	1.07	27.18	0.92	23.37	1.29	32.77
16	17	17 / E	1.25	31.75	0.69	17.45	0.76	19.30	0.73	18.59	1.09	27.69	0.98	24.89	1.35	34.29
18	19	19 / F	1.40	35.56	0.81	20.62	0.89	22.61	0.75	19.00	1.10	27.94	1.02	25.91	1.37	34.80
20	21	21 / G	1.50	38.10	0.94	23.80	1.01	25.65	0.77	19.63	1.12	28.45	1.08	27.43	1.43	36.32
22	23	23 / H	1.65	41.91	1.05	26.57	1.13	28.70	0.80	20.32	1.16	29.46	1.14	28.96	1.51	38.35
24	25	25 / J	1.75	44.45	1.13	28.58	1.20	30.53	0.82	20.90	1.19	30.23	1.20	30.48	1.58	40.13

TABLE - B												
S.A.E. PART NUMBER DESIGNATOR		CONNECTOR SHELL SIZE	X DIA.				Y DIA.				Z	
DASH NO.	PART NO COLOR		MIN		MAX		MIN		MAX		INCH	MM
			INCH	MM	INCH	MM	INCH	MM	INCH	MM		
08	GREEN	8	0.45	11.38	0.46	11.63	0.40	10.16	0.41	10.41	0.25	6.35
10	RED	10	0.66	16.76	0.68	17.27	0.59	14.86	0.60	15.11	0.44	11.18
12	RED	7/12	0.66	16.76	0.68	17.27	0.59	14.86	0.60	15.11	0.44	11.18
14	BLUE	12/14	0.78	19.81	0.80	20.32	0.71	17.91	0.72	18.16	0.44	11.18
16	GRAY	19/16	0.91	23.11	0.93	23.62	0.84	21.21	0.85	21.46	0.44	11.18
18	BROWN	27/18	1.08	27.43	1.10	27.94	1.01	25.53	1.02	25.78	0.44	11.18
20	GREEN	37/20	1.20	30.48	1.22	30.99	1.13	28.58	1.14	28.83	0.44	11.18
22	PINK	22	1.32	33.53	1.34	34.04	1.25	31.62	1.26	31.88	0.44	11.18
24	YELLOW	24	1.39	35.23	1.41	35.74	1.31	33.32	1.32	33.58	0.44	11.18
28	RED	28	1.74	44.20	1.76	44.70	1.67	42.29	1.68	42.55	0.44	11.18
32	GRAY	32	1.99	50.55	2.01	51.05	1.92	48.64	1.93	48.90	0.44	11.18
36	GREEN	36	2.24	56.90	2.26	57.40	2.17	54.99	2.18	55.25	0.44	11.18
40	ORANGE	40	2.49	63.25	2.51	63.75	2.42	61.34	2.43	61.60	0.44	11.18
44	YELLOW	44	2.74	69.60	2.76	70.10	2.67	67.69	2.68	67.95	0.44	11.18
48	BLUE	48	2.99	75.95	3.01	76.45	2.92	74.04	2.93	74.30	0.44	11.18

Material and finish for the crimp ring will always be as follows

Material as per ASTM B-75

Finish as per MIL-T-10727, Type-1

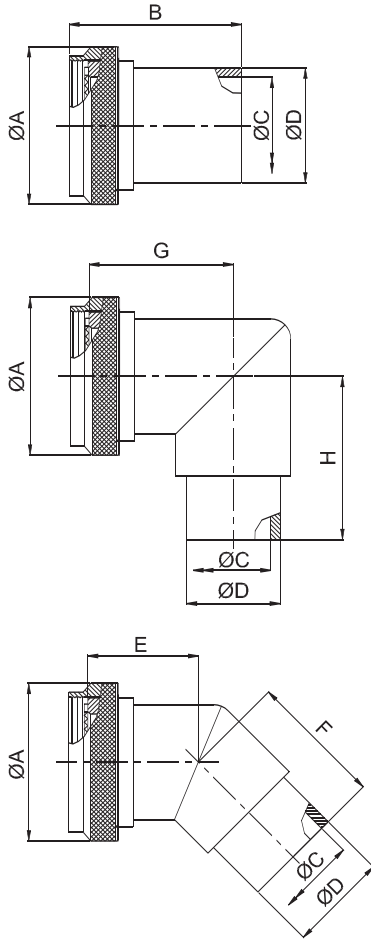

### Amphenol Part Number

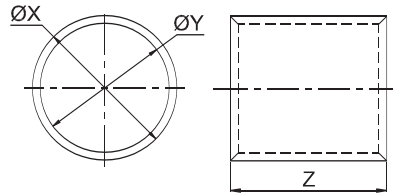
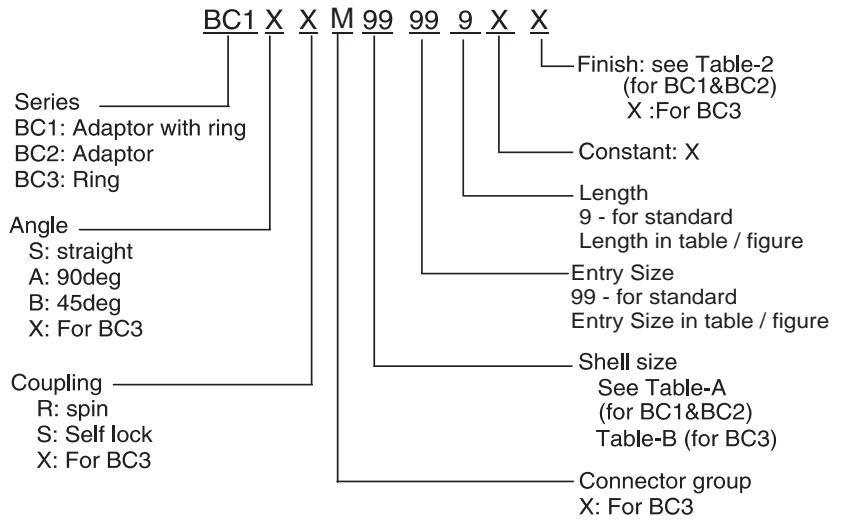

NOTE: \* For more cable entry and length options, contact factory

TABLE - A

AMPHENOL PART NUMBER DESIGNATOR	CONNECTOR SHELL SIZE	A DIA. ( MAX)		B (MAX)		C DIA. ( MAX)		D DIA. (MAX)		E ( MAX)		F ( MAX)		G ( MAX)		H ( MAX)	
		INCH	MM	INCH	MM	INCH	MM	INCH	MM	INCH	MM	INCH	MM	INCH	MM	INCH	MM
08	8 / 9	0.75	19.05	1.14	28.96	0.27	6.86	0.35	8.89	0.64	16.23	0.70	17.83	0.75	19.05	0.81	20.62
10	10 / 11	0.85	21.59	1.14	28.96	0.34	8.64	0.50	12.70	0.66	16.87	0.73	18.59	0.81	20.62	0.88	22.23
12	12 / 13	1.00	25.40	1.14	28.96	0.44	11.18	0.51	12.95	0.69	17.48	1.04	26.42	0.88	22.23	1.22	30.99
14	14 / 15	1.10	27.94	1.14	28.96	0.56	14.22	0.63	16.00	0.71	17.91	1.07	27.18	0.92	23.37	1.29	32.77
16	16 / 17	1.25	31.75	1.14	28.96	0.69	17.53	0.76	19.30	0.73	18.59	1.09	27.69	0.98	24.89	1.35	34.29
18	18 / 19	1.40	35.56	1.14	28.96	0.80	20.32	0.89	22.61	0.75	19.00	1.10	27.94	1.02	25.91	1.37	34.80
20	20 / 21	1.50	38.10	1.14	28.96	0.93	23.62	1.01	25.65	0.77	19.63	1.12	28.45	1.08	27.43	1.43	36.32
22	22 / 23	1.65	41.91	1.14	28.96	1.05	26.67	1.13	28.70	0.80	20.32	1.16	29.46	1.14	28.96	1.51	38.35
24	24 / 25	1.75	44.45	1.14	28.96	1.13	28.70	1.20	30.48	0.82	20.90	1.19	30.23	1.20	30.48	1.58	40.13



TABLE - B												
MIL PART NUMBER DESIGNATOR		CONNECTOR SHELL SIZE	X DIA.				Y DIA.				Z	
DASH NO.	PART NO COLOR		MIN		MAX		MIN		MAX		INCH	MM
			INCH	MM	INCH	MM	INCH	MM	INCH	MM		
08	GREEN	8	0.45	11.38	0.46	11.63	0.40	10.16	0.41	10.41	0.25	6.35
10	RED	10	0.66	16.76	0.68	17.27	0.59	14.86	0.60	15.11	0.44	11.18
12	RED	7/12	0.66	16.76	0.68	17.27	0.59	14.86	0.60	15.11	0.44	11.18
14	BLUE	12/14	0.78	19.81	0.80	20.32	0.71	17.91	0.72	18.16	0.44	11.18
16	GRAY	19/16	0.91	23.11	0.93	23.62	0.84	21.21	0.85	21.46	0.44	11.18
18	BROWN	27/18	1.08	27.43	1.10	27.94	1.01	25.53	1.02	25.78	0.44	11.18
20	GREEN	37/20	1.20	30.48	1.22	30.99	1.13	28.58	1.14	28.83	0.44	11.18
22	PINK	22	1.32	33.53	1.34	34.04	1.25	31.62	1.26	31.88	0.44	11.18
24	YELLOW	24	1.39	35.23	1.41	35.74	1.31	33.32	1.32	33.58	0.44	11.18
28	RED	28	1.74	44.20	1.76	44.70	1.67	42.29	1.68	42.55	0.44	11.18
32	GRAY	32	1.99	50.55	2.01	51.05	1.92	48.64	1.93	48.90	0.44	11.18
36	GREEN	36	2.24	56.90	2.26	57.40	2.17	54.99	2.18	55.25	0.44	11.18
40	ORANGE	40	2.49	63.25	2.51	63.75	2.42	61.34	2.43	61.60	0.44	11.18
44	YELLOW	44	2.74	69.60	2.76	70.10	2.67	67.69	2.68	67.95	0.44	11.18
48	BLUE	48	2.99	75.95	3.01	76.45	2.92	74.04	2.93	74.30	0.44	11.18

Material and finish for the crimp ring will always be as follows

Material as per ASTM B-75

Finishing as per MIL-T-10727, Type-1

Connector Group - N

Straight, 90°, 45°

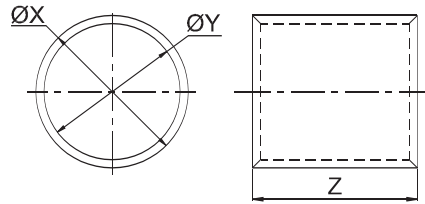
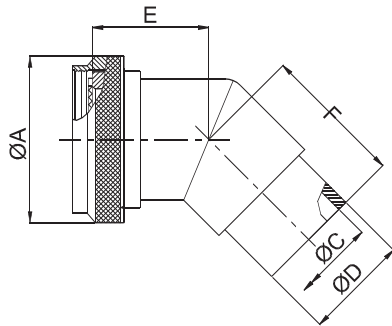
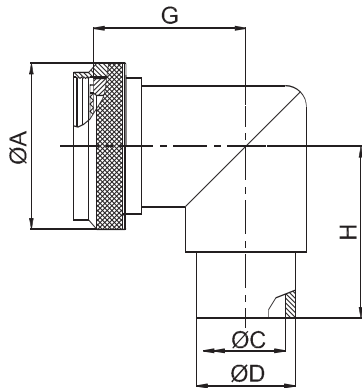
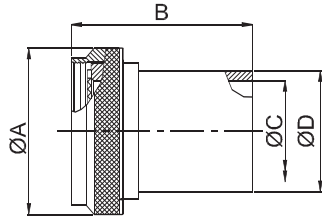

### Amphenol Part Number

BC1 X X N 99 99 9 X X

Series  
 BC1: Adaptor with ring  
 BC2: Adaptor  
 BC3: Ring

Angle  
 S: straight  
 A: 90deg  
 B: 45deg  
 X: For BC3

Coupling  
 R: spin  
 S: Self lock  
 X: For BC3

Finish: see Table-2 (for BC1&BC2)  
 X: For BC3

Constant: X

Length  
 9 - for standard  
 Length in table / figure

Entry Size  
 99 - for standard  
 Entry Size in table / figure

Shell size  
 See Table-A (for BC1&BC2)  
 Table-B (for BC3)

Connector group  
 X: For BC3

NOTE: \* For more cable entry and length options, contact factory

TABLE - A																	
AMPHENOL PART NUMBER DESIGNATOR	CONNECTOR SHELL SIZE	A DIA. ( MAX)		B (MAX)		C DIA. ( MAX)		D DIA. (MAX)		E ( MAX)		F ( MAX)		G ( MAX)		H ( MAX)	
		INCH	MM	INCH	MM	INCH	MM	INCH	MM	INCH	MM	INCH	MM	INCH	MM	INCH	MM
08	8 / 9	0.75	19.05	1.14	28.96	0.27	6.86	0.35	8.89	0.64	16.23	0.70	17.83	0.75	19.05	0.81	20.62
10	10 / 11	0.85	21.59	1.14	28.96	0.34	8.64	0.50	12.70	0.66	16.87	0.73	18.59	0.81	20.62	0.88	22.23
12	12 / 13	1.00	25.40	1.14	28.96	0.44	11.18	0.51	12.95	0.69	17.48	1.04	26.42	0.88	22.23	1.22	30.99
14	14 / 15	1.10	27.94	1.14	28.96	0.56	14.22	0.63	16.00	0.71	17.91	1.07	27.18	0.92	23.37	1.29	32.77
16	16 / 17	1.25	31.75	1.14	28.96	0.69	17.53	0.76	19.30	0.73	18.59	1.09	27.69	0.98	24.89	1.35	34.29
18	18 / 19	1.40	35.56	1.14	28.96	0.80	20.32	0.89	22.61	0.75	19.00	1.10	27.94	1.02	25.91	1.37	34.80
20	20 / 21	1.50	38.10	1.14	28.96	0.93	23.62	1.01	25.65	0.77	19.63	1.12	28.45	1.08	27.43	1.43	36.32
22	22 / 23	1.65	41.91	1.14	28.96	1.05	26.67	1.13	28.70	0.80	20.32	1.16	29.46	1.14	28.96	1.51	38.35
24	24 / 25	1.75	44.45	1.14	28.96	1.13	28.70	1.20	30.48	0.82	20.90	1.19	30.23	1.20	30.48	1.58	40.13



TABLE - B

AMPHENOL PART NUMBER DESIGNATOR	MIL PART NUMBER DESIGNATOR		CONNECTOR SHELL SIZE SIZE	X DIA.				Y DIA.				Z	
				MIN		MAX		MIN		MAX		INCH	MM
				INCH	MM	INCH	MM	INCH	MM	INCH	MM		
08	08	GREEN	8	0.45	11.38	0.46	11.63	0.40	10.16	0.41	10.41	0.25	6.35
10	10	RED	10	0.66	16.76	0.68	17.27	0.59	14.86	0.60	15.11	0.44	11.18
12	12	RED	7/12	0.66	16.76	0.68	17.27	0.59	14.86	0.60	15.11	0.44	11.18
14	14	BLUE	12/14	0.78	19.81	0.80	20.32	0.71	17.91	0.72	18.16	0.44	11.18
16	16	GRAY	19/16	0.91	23.11	0.93	23.62	0.84	21.21	0.85	21.46	0.44	11.18
18	18	BROWN	27/18	1.08	27.43	1.10	27.94	1.01	25.53	1.02	25.78	0.44	11.18
20	20	GREEN	37/20	1.20	30.48	1.22	30.99	1.13	28.58	1.14	28.83	0.44	11.18
22	22	PINK	22	1.32	33.53	1.34	34.04	1.25	31.62	1.26	31.88	0.44	11.18
24	24	YELLOW	24	1.39	35.23	1.41	35.74	1.31	33.32	1.32	33.58	0.44	11.18
28	28	RED	28	1.74	44.20	1.76	44.70	1.67	42.29	1.68	42.55	0.44	11.18
32	32	GRAY	32	1.99	50.55	2.01	51.05	1.92	48.64	1.93	48.90	0.44	11.18
36	36	GREEN	36	2.24	56.90	2.26	57.40	2.17	54.99	2.18	55.25	0.44	11.18
40	40	ORANGE	40	2.49	63.25	2.51	63.75	2.42	61.34	2.43	61.60	0.44	11.18
44	44	YELLOW	44	2.74	69.60	2.76	70.10	2.67	67.69	2.68	67.95	0.44	11.18
48	48	BLUE	48	2.99	75.95	3.01	76.45	2.92	74.04	2.93	74.30	0.44	11.18

**Note:** The material & finish for the crimp ring will always be as follows

Material: Copper as per ASTM B-75

Finish: Tin plating as per MIL-T-10727, Type-1