

SJS80110P

REV	ECN	APP'D
-	7754	JT 5/6/16
A	7801	JT 11/22/16
B	8000	MD 4/26/17

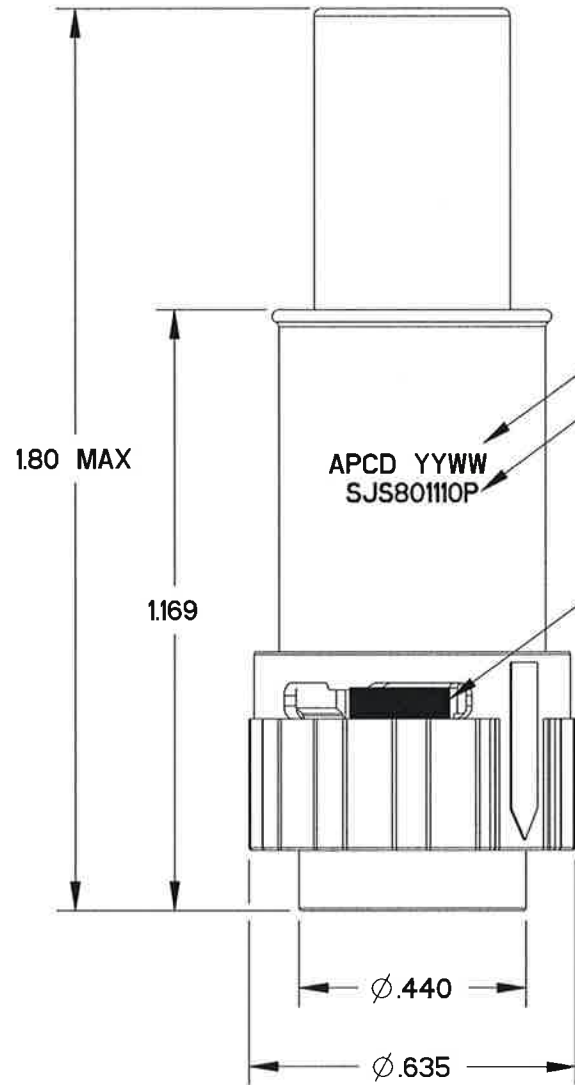

DATE CODE
 PART MARKING
 FONT HEIGHT: .05
 COLOR: BLACK
 APCD YYWW
 SJS80110P
 RED MARKING VISIBLE
 IN OPEN POSITION
 TWO SIDES

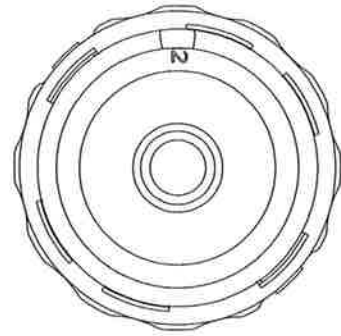
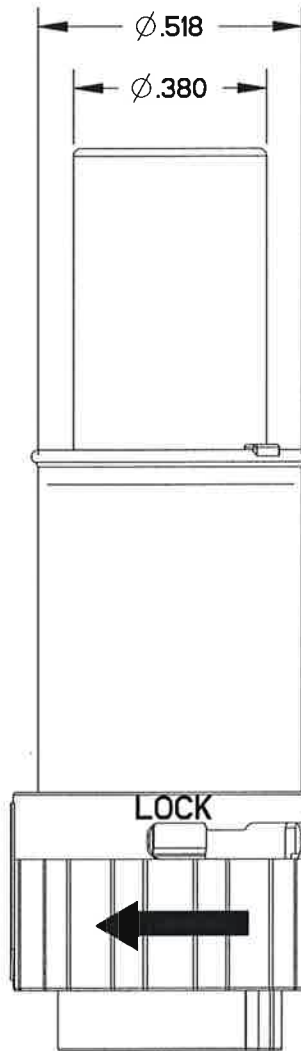

RED MARKING NOT VISIBLE
 IN CLOSED POSITION
 TWO SIDES

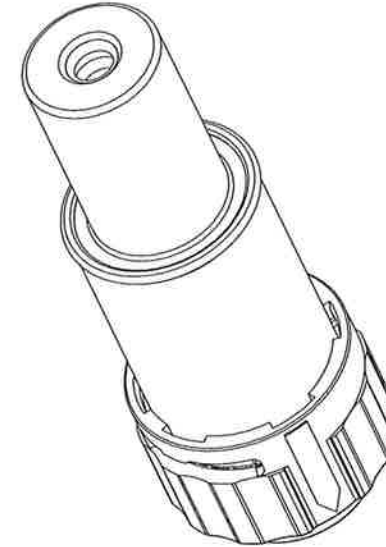

NOTES:

- 1. MATERIALS:
 HOUSING: ULTEM CRS5011, COLOR: BLACK
 COUPLING NUT: PA66, COLOR: BLACK
 CONTACT RETAINER: STAINLESS STEEL
 SEALING BOOT: SILICONE RUBBER PER A-A-59588, COLOR: BLUE
 EMI SPRING: BERYLLIUM COPPER
- 2. FINISH:
 HOUSING: NICKEL, 200 MICROINCHES MINIMUM
 OVER COPPER, 120 MICROINCHES MINIMUM
 EMI SPRING: NICKEL, 100 MICROINCHES MINIMUM
- 3. ACCEPTS CONTACTS PER TABLE 1 (SHEET 2)
- 4. SEALING BOOT IS INSTALLED IN WIRE END,
 REMOVE BEFORE ASSEMBLY OF CONTACT
- 5. PART MATES WITH SJS801120P(-X)
- 6. WEIGHT: 5.2 GRAMS
- 7. SUPPLIED WITH DUST CAP

DIMENSIONS ANSI Y14.5M UNITS: INCHES Pro/E FILE	TOLERANCES .XX ±0.01 .XXX ±0.005 ANGLES ±2.0°	PROJECTION 	Amphenol Pcd SPECIFICATION DRAWING		TITLE INLINE PLUG SJS PEGASUS HIGH SPEED SHELL SIZE 8, ONE POS SIZE 8		
			ENGR Mickey.Zhang Jul-15-15			SIZE B	DWG NO. SJS80110P
ORIGINAL	THIS DOCUMENT CONTAINS PROPRIETARY INFORMATION WHICH IS THE CONFIDENTIAL PROPERTY OF AMPHENOL PCD INC., BEVERLY, MA		CHKD APPD 4/26/17	CODE: 58982		SCALE: 8:3	SHEET 1 OF 2

SJS80110P

SJS80110P

TABLE I: ORDERING OPTIONS					MATING RECEPTACLE	
CONTACT TYPE	APCD KIT PN	CONTACT PN	SUPPORTED CABLE TYPE(S)	IMPEDANCE (Ω)	APCD KIT PN	CONTACT PN
CONNECTOR ONLY	SJS801110P	NONE SUPPLIED	REFERENCE(S) BELOW	REFERENCE(S) BELOW	SJS801120P	NONE SUPPLIED
POWER	SJS801110P-1	CNS808100	8 - 10 AWG	N/A	SJS801120P-1	CNP808100
DIFFERENTIAL TWINAX	SJS801110P-2	CNS882100	ABS0386WF24	100	SJS801120P-2	CNP882100
	SJS801110P-3	CNS882110	ASNE0272TK22	100	SJS801120P-3	CNP882110
	SJS801110P-4	CNS882120	ASNE0272TK24	100	SJS801120P-4	CNP882120
	SJS801110P-5	CNS882130	ASNE0807WX26	100	SJS801120P-5	CNP882130
	SJS801110P-6	CNS882140	TENSOLITE 24463/9P025X-2(LD)	100	SJS801120P-6	CNP882140
	SJS801110P-7	CNS882150	GC875TM24H	77	SJS801120P-7	CNP882150
QUADRAX	SJS801110P-8	CNS882200	ABS0972, ABS1503KD24	100	SJS801120P-8	CNP882300
	SJS801110P-9	CNS882210	TENSOLITE NF24Q100, NF24Q100-01, NF24Q100-01-200C, 24443/9P025X-4(LD), 24443/03130X-4(LD), 24443/0120X-4(LD), 24443/03166X-4(LD); TYCO CECRWC-18664; GORE GSC-01-81869-01; THERMAX T956-4T200, MX100Q-24; PIC WIRE E51424; S280W502-4, BMS1372T03C04G024	100	SJS801120P-9	CNP882310
	SJS801110P-10	CNS882220	DRAKA FILECA F4703-3	100	SJS801120P-10	CNP882320
	SJS801110P-11	CNS882230	TENSOLITE 26473/02006X-4(LD); GORE RCN8328	150	SJS801120P-11	CNP882330
	SJS801110P-12	CNS882240	JSFY02-1	110	SJS801120P-12	CNP882340
	SJS801110P-13	CNS882250	TENSOLITE NF22Q100; DRAKA FILECA F4704-5	100	SJS801120P-13	CNP882350

SIZE	DWG NO.	REV
B	SJS801110P	B
CODE: 58982	SCALE: 8:3	SHEET 2 OF 2