

DANS LE BUT CONSTANT D'AMELIORER SES PRODUITS, Amphenol Socapex SE RESERVE LE DROIT D'EN MODIFIER TOUTE COTE OU CARACTERISTIQUE.  
IMP 037 A

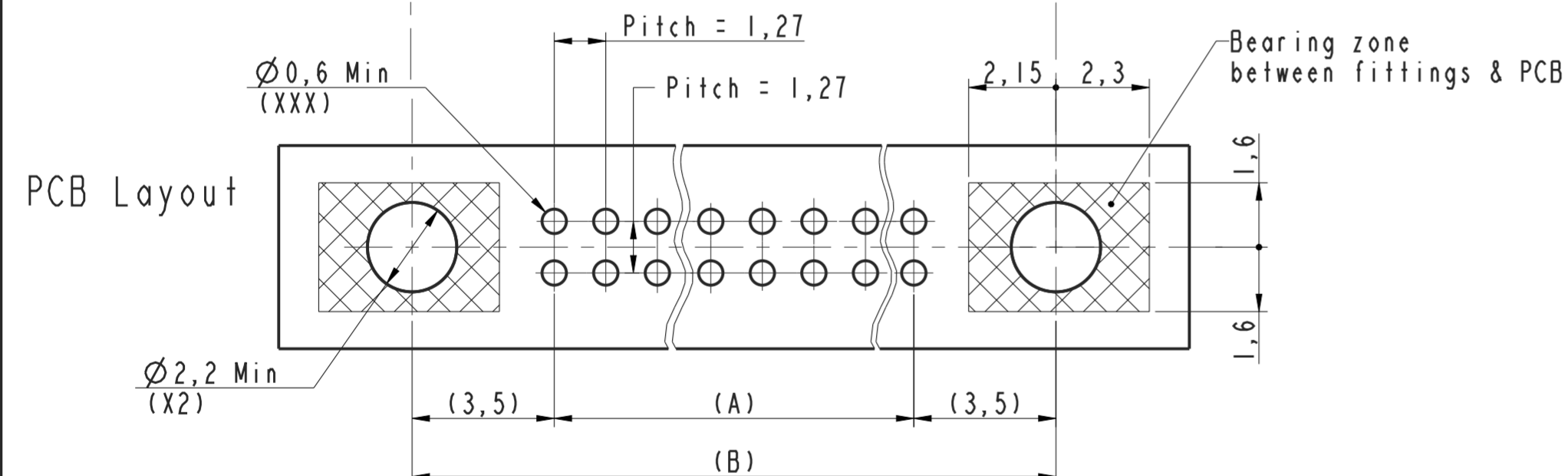
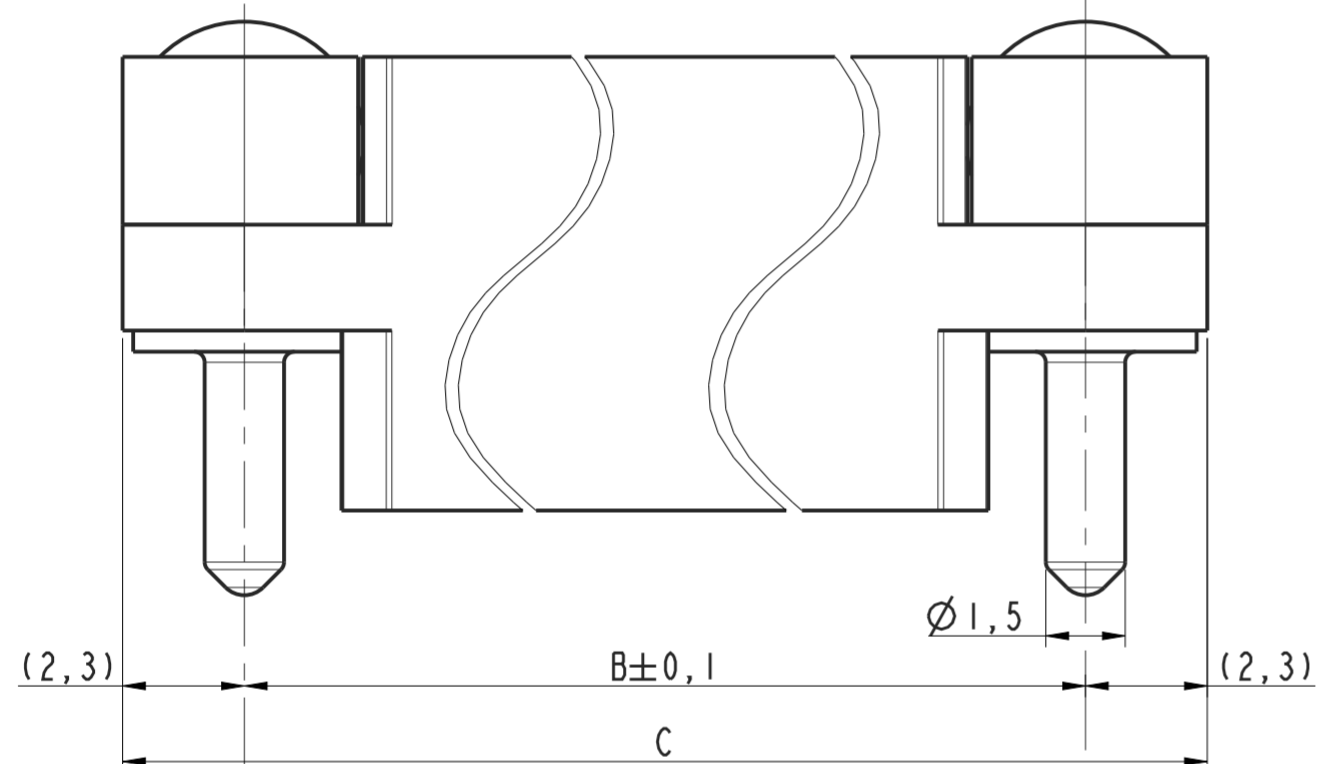
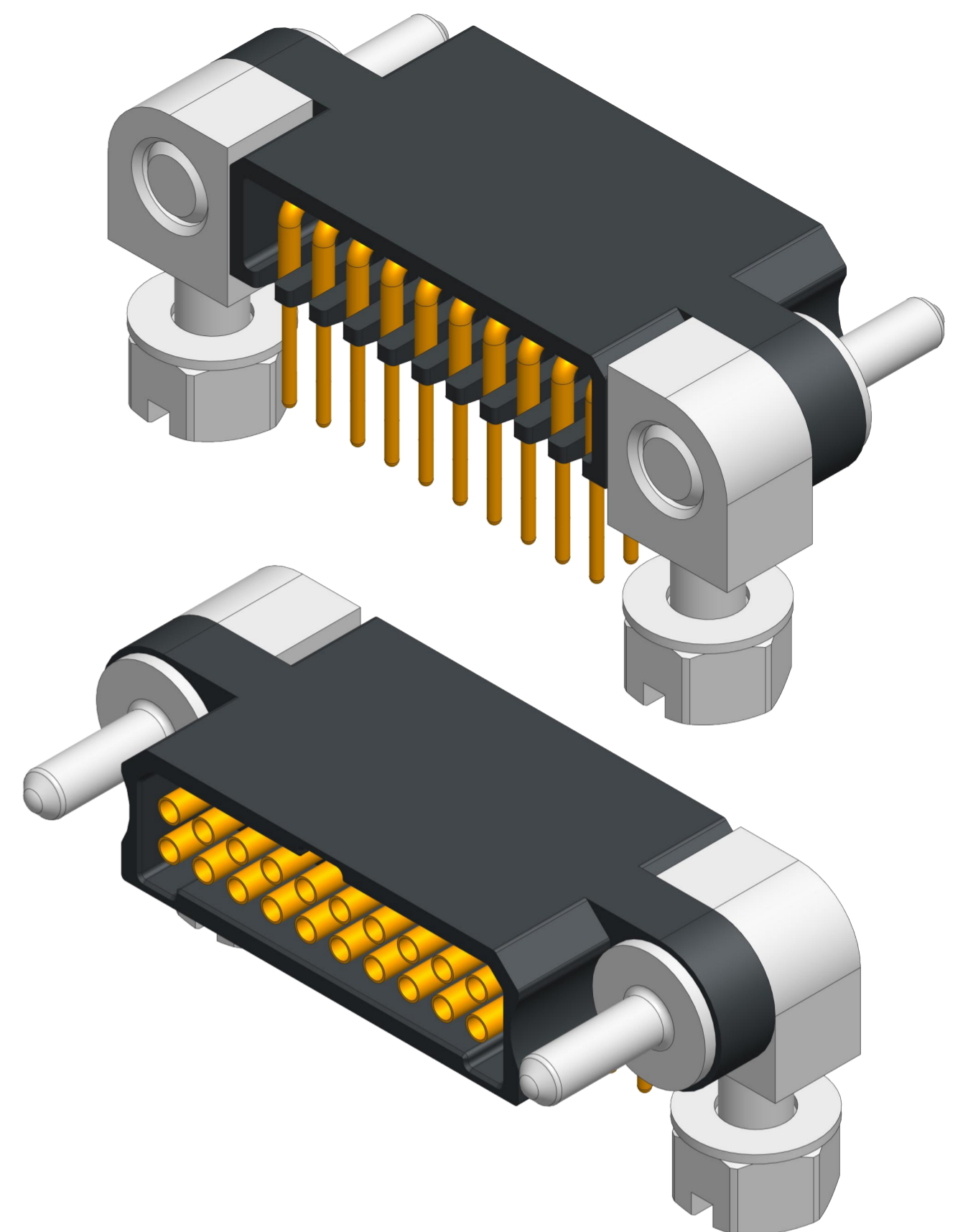
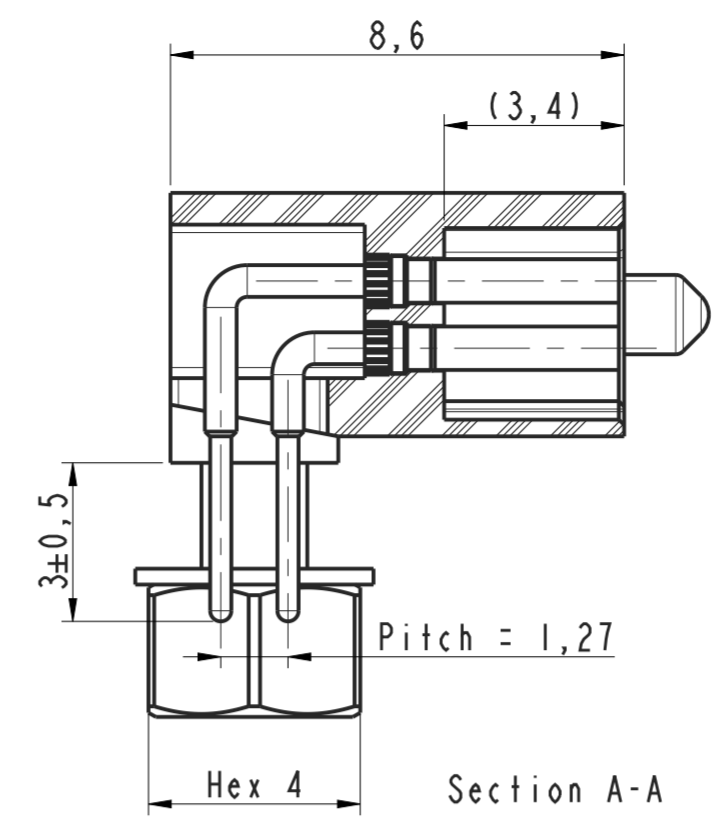
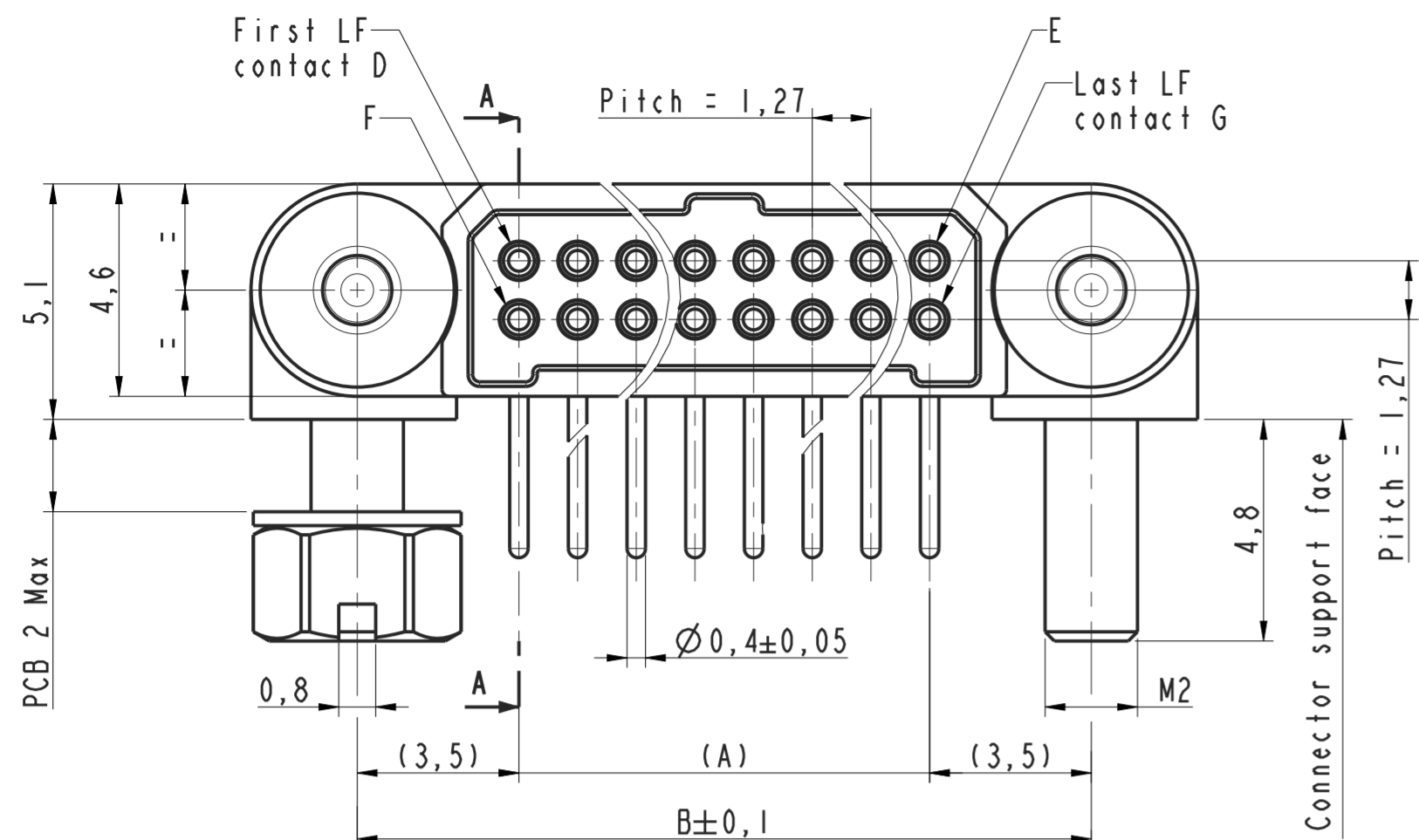

- Notes:
- "XXX" to be replaced by the number of LF contacts.
  - MHDAS is fully intermateable and intermountable with EMM connector (EMM is a NICOMATIC trademark)
  - Connector delivered with fittings not assembled, coupling torque: 0,3 Nm
  - General tolerance  $\pm 0,2$
  - Fittings material : Passivated stainless steel
  - Contacts material : Body: Copper alloy ; Clip: Beryllium copper
  - Insulator material : LCP (Liquid Crystal Polymer) UL94-V0

LF Contacts number	Distance in mm between axes		Length in mm	LF Contacts reference mark number			
	A	B		D	E	F	G
XXX	A	B	C	D	E	F	G
004	1,27	8,27	12,87	1	2	3	4
008	3,81	10,81	15,41	1	4	5	8
016	8,89	15,89	20,49	1	8	9	16
020	11,43	18,43	23,03	1	10	11	20
026	15,24	22,24	26,84	1	13	14	26
030	17,78	24,78	29,38	1	15	16	30
040	24,13	31,13	35,73	1	20	21	40
050	30,48	37,48	42,08	1	25	26	50
060	36,83	43,83	48,43	1	30	31	60

**MICRO HDAS**  
 Female connector  
**MHDAS 2 F XXX YC E I I**

MODIFICATIONS	A	Plan original	ECHELLE	Amphenol Socapex BP 29 - 74311 THYEZ CEDEX	DESSIN: S Saute	LE: 15/10/19
			7		TECHNIQUE: T Dabbabi	LE: 15/10/19
					A	
					169-PLC-1512-00 1/1	