

## ARINC 600 Trays



ARINC 600 8 MCU Tray with Side-Mounted Fan and Plenum Chamber

### INTRODUCTION

All ARINC 600 Trays are designed and fabricated in our state-of-the-art manufacturing facility using top quality aircraft-grade materials to meet or exceed ARINC 600 specifications, as well as all civil and military aircraft application criteria. Our special designs stand up to the most rigorous environmental hazards for in-flight and on-the-ground operations. Each tray is fully warranted, ensuring that your avionics systems equipment will not only fit securely, but also operate safely. Off-the-shelf designs or custom solutions, as well as the option of positive pressure air cooling systems through the use of an optional plenum chamber and fan, are available to best fit your requirements.

### APPLICATIONS

- » ARINC 600 Standards
- » CFR Title 14 Part 25, 23, & 21
- » RTCA/DO-160
- » MIL-STD-810

### FEATURES

- » Durable, rugged construction
- » Light-weight aluminum alloy
- » 24-hour AOG support
- » Fan-cooled trays conform to ARINC Level 1 maximum cooling specifications (Level 2 cooling is available if required). Cooling fans can be ordered with AC or DC power supply.
- » Available with ARINC 600 air filtration solutions
- » Clear Chem Film per MIL-DTL-5541, Type II, Class 3
- » Materials meet flammability, optical smoke density, and toxic gas generation requirements
- » RoHS compliant in standard configurations

### SERVICES

- » Structural analysis
- » Shock & vibration testing
- » Crash safety testing
- » Finite element analysis
- » Flammability testing
- » Environmental testing
- » Air flow & cooling analysis & testing

# ARINC 600 Trays

## SUGGESTED APPLICATIONS

The following cut-away diagrams illustrate standard front and rear-mounting hole placement for ARINC 600 Trays. No. 10 mounting holes are standard on all trays. No. 8 mounting holes are available as an option. Note: Dimensions are in inches, bracketed [numbers] represent millimeters.

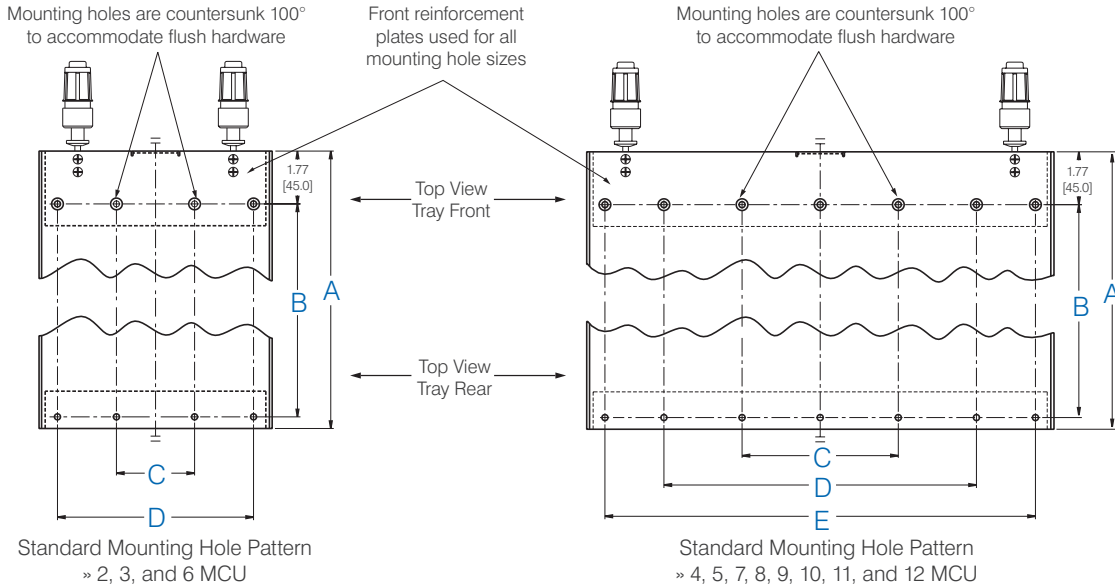

## MOUNTING DIMENSIONS REFERENCE CHART

MCU Size	A	B	C	D	E
2	14.92 [379.0]	12.76 [324.1]	1.312 [33.3]	-	-
2	20.06 [509.5]	18.00 [457.2]	1.312 [33.3]	-	-
3	14.92 [379.0]	12.76 [324.1]	2.624 [66.6]	-	-
3	20.06 [509.5]	18.00 [457.2]	2.624 [66.6]	-	-
4	14.92 [379.0]	12.76 [324.1]	3.936 [100.0]	-	-
4	20.06 [509.5]	18.00 [457.2]	3.936 [100.0]	-	-
5	14.92 [379.0]	12.76 [324.1]	5.248 [133.3]	-	-
5	20.06 [509.5]	18.00 [457.2]	5.248 [133.3]	-	-
6	14.92 [379.0]	12.76 [324.1]	2.624 [66.6]	6.560 [166.6]	-
6	20.06 [509.5]	18.00 [457.2]	2.624 [66.6]	6.560 [166.6]	-
7	14.92 [379.0]	12.76 [324.1]	5.248 [133.3]	7.872 [199.9]	-
7	20.06 [509.5]	18.00 [457.2]	5.248 [133.3]	7.872 [199.9]	-
8	14.92 [379.0]	12.76 [324.1]	5.248 [133.3]	9.184 [233.3]	-
8	20.06 [509.5]	18.00 [457.2]	5.248 [133.3]	9.184 [233.3]	-
9	14.92 [379.0]	12.76 [324.1]	5.248 [133.3]	10.496 [266.6]	-
9	20.06 [509.5]	18.00 [457.2]	5.248 [133.3]	10.496 [266.6]	-
10	14.92 [379.0]	12.76 [324.1]	5.248 [133.3]	11.808 [299.9]	-
10	20.06 [509.5]	18.00 [457.2]	5.248 [133.3]	11.808 [299.9]	-
11	14.92 [379.0]	12.76 [324.1]	5.248 [133.3]	13.120 [333.2]	-
11	20.06 [509.5]	18.00 [457.2]	5.248 [133.3]	13.120 [333.2]	-
12	14.92 [379.0]	12.76 [324.1]	5.248 [133.3]	10.496 [266.6]	14.432 [366.6]
12	20.06 [509.5]	18.00 [457.2]	5.248 [133.3]	10.496 [266.6]	14.432 [366.6]

# ARINC 600 Trays

## DIMENSIONAL DATA

### Short/Short and Short/Long Trays

Note: Dimensions are in inches, bracketed [numbers] represent millimeters.

#### Typical Side View

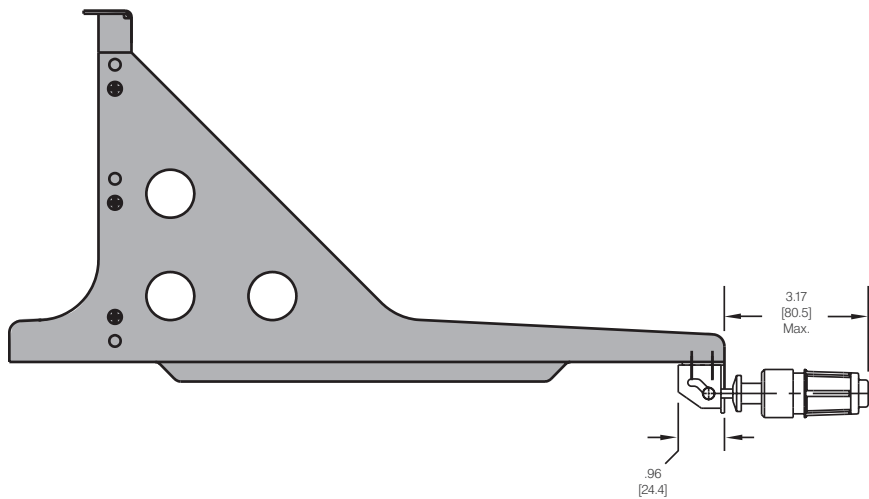

#### Typical Top View

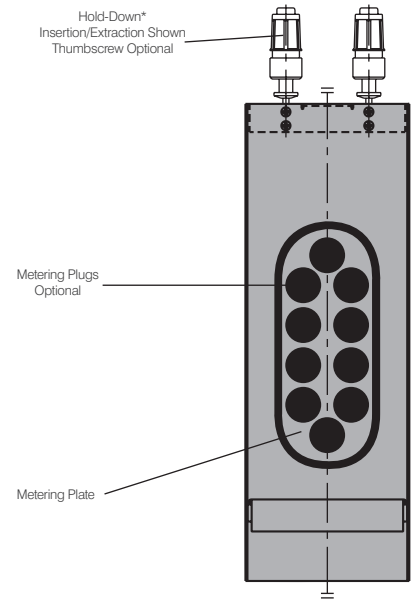

MCU Size	A (Outside Dimensions)
1 MCU	1.22 [31.0]
2 MCU	2.51 [63.8]
3 MCU	3.81 [96.8]
4 MCU	5.13 [130.3]
5 MCU	6.43 [163.3]
6 MCU	7.73 [196.3]
7 MCU	9.03 [229.4]
8 MCU	10.33 [262.4]
9 MCU	11.63 [295.4]
10 MCU	12.93 [328.4]
11 MCU	14.23 [361.4]
12 MCU	15.53 [394.5]

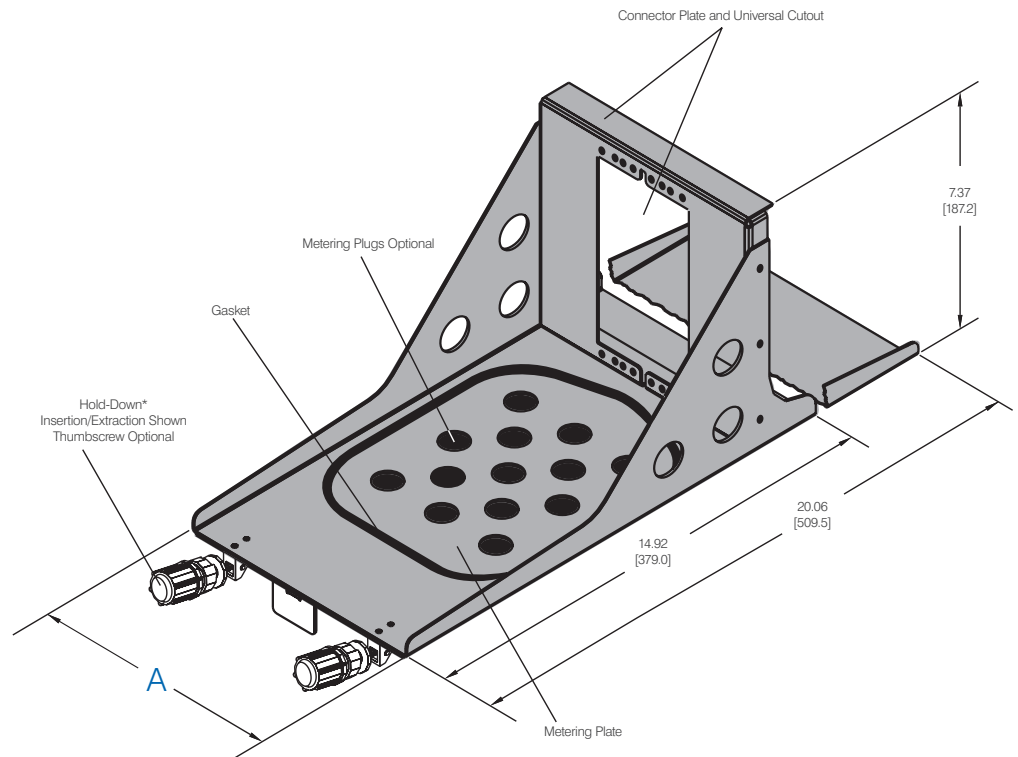

\*Thumbscrew Hold-Down options include: Insertion/Extraction, Advanced Thumbscrew, and Military-Style Thumbscrew. All dimensions shown represent Amphenol CIT's standard tray dimensions and frequently requested options. Amphenol CIT can customize any of these features to suit your specific needs.

# ARINC 600 Trays

## OPTIONS & ACCESSORIES

### Hold-Downs

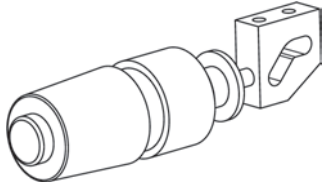

Insertion/Extraction

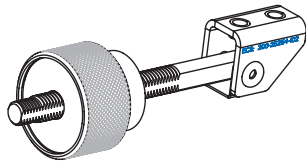

Advanced Thumbscrew

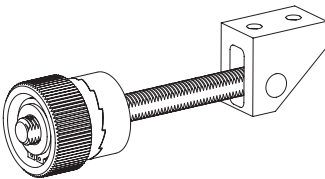

Military-Style Thumbscrew

### Metering Plugs & Reducing Grommets

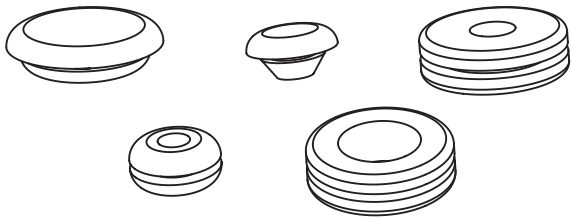

### Shock & Vibration Isolators

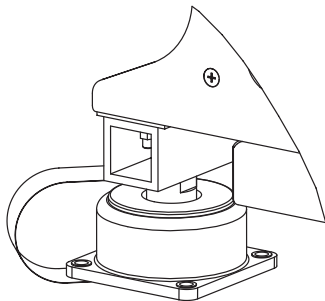

### Positive Pressure Air Filters\*

\*Negative Pressure Air Filters available

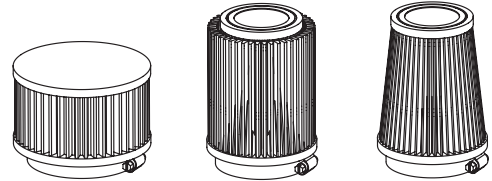

### Cooling Fans & Integrated Plenums

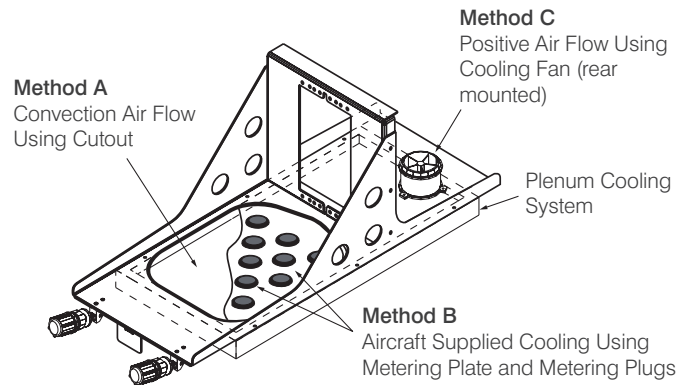

### Fan Failure Monitoring, Grounding Features & Terminal Blocks

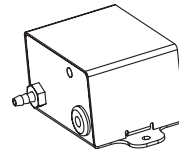
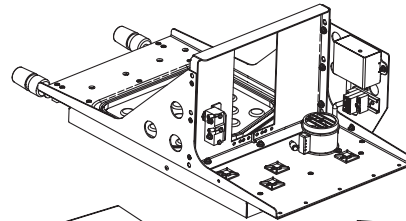

Fan Failure Sensor

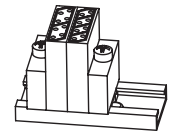

Terminal Blocks

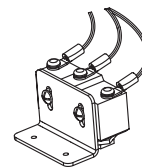

Ground Module

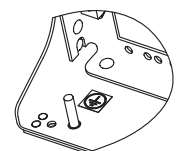

Ground Stud