

NOTES:

1. THE CLEANING KIT FOR THE ARES REEL IS INCLUDED WITH THE TRANSIT CASE. THE CLEANING KIT CAN BE ORDERED SEPARATELY (SEE ARES-CK DWG)
2. REELS MEET THE REQUIREMENTS FOR PERFORMANCE, SIZE, WEIGHT, COLOR, TEMPERATURE, CABLE CAPACITY AND STORAGE AS CALLED OUT ON SPECIFICATION A336463A
3. GRAY COLOR AVAILABLE IN 3000 METER REEL ONLY

REVISION HISTORY - ALL SHEETS ARE THE SAME REVISION

REV	DESCRIPTION	DATE	APPROVED
	ENGINEERING RELEASE		
	FORMAL RELEASE		
A	ECN 160426-0840, MH	2016/04/26	JW
B	ECN 170111-1111, XLT	2017/02/02	JW

PRODUCT NUMBER IDENTIFICATION  
ARES-XXXX-

REEL SIZE  
300  
500  
750  
1000  
3000

HANDLE OPTION  
1 - HANDLE  
2 - NO HANDLE

REEL COLOR OPTION  
T - TAN  
D - OLIVE DRAB  
B - BLACK  
Y - GRAY 3

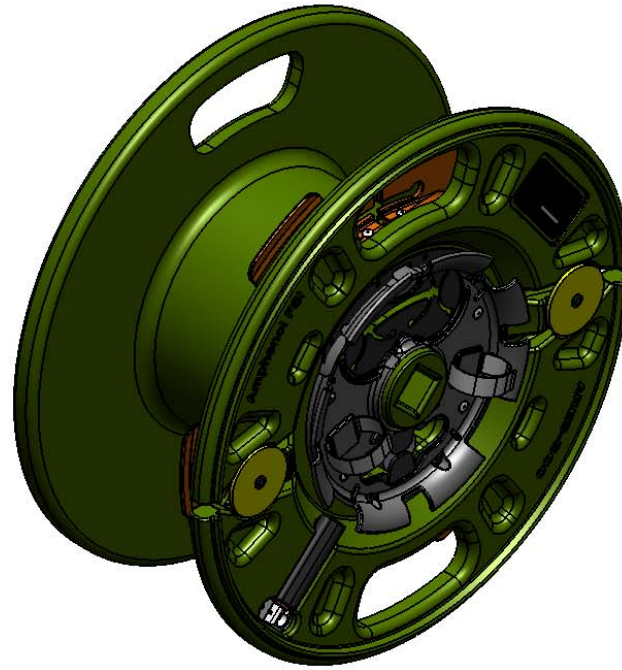

PRODUCT DRAWING

DFT	MH	2016/02/25
ENG	MH	2016/03/04
CHK	JW	2016/03/04
APP	CJ	2016/04/26



TITLE  
DEPLOYABLE FIBER OPTIC REEL SYSTEM

DO NOT SCALE DRAWING  
UNLESS OTHERWISE SPECIFIED  
DIM ARE IN INCHES  
TOL ON ANGLES ±3°  
4-PL ±.1 - 2-PL ±.02 - 3-PL ±.010  
-INTERPRET DIM AND TOL PER  
-ASME Y14.5-2009-

SIZE	CAGE CODE	DWG NO	REV
C	ØYPM2	ARES-XXXX	B
SCALE	3:8	SHEET	1 OF 3

4

3

2

1

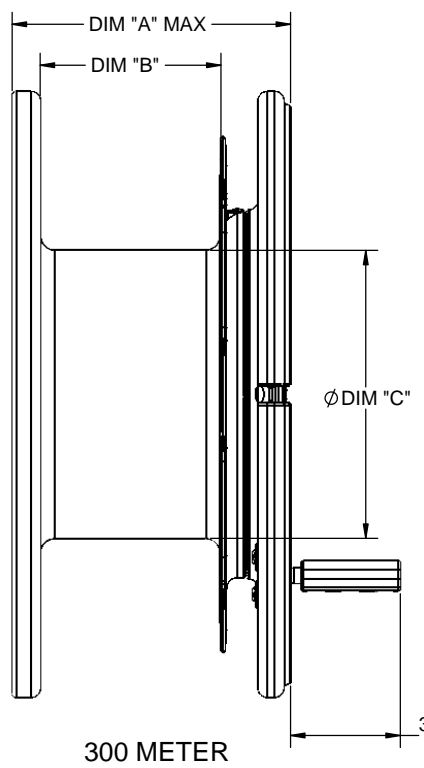

3.05  
HANDLE EXTENDED

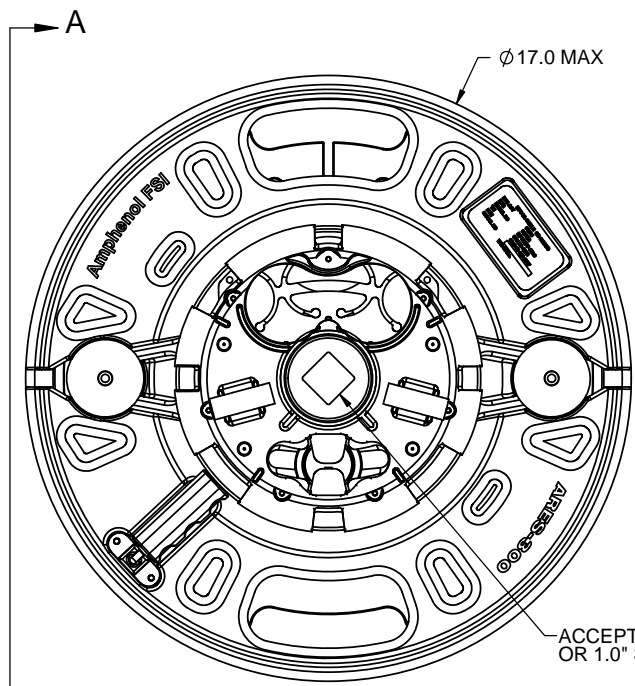
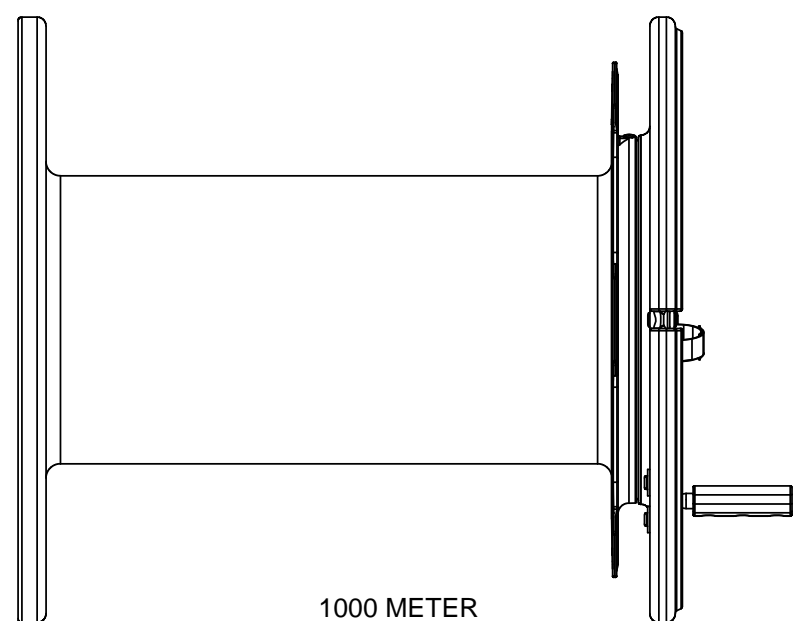
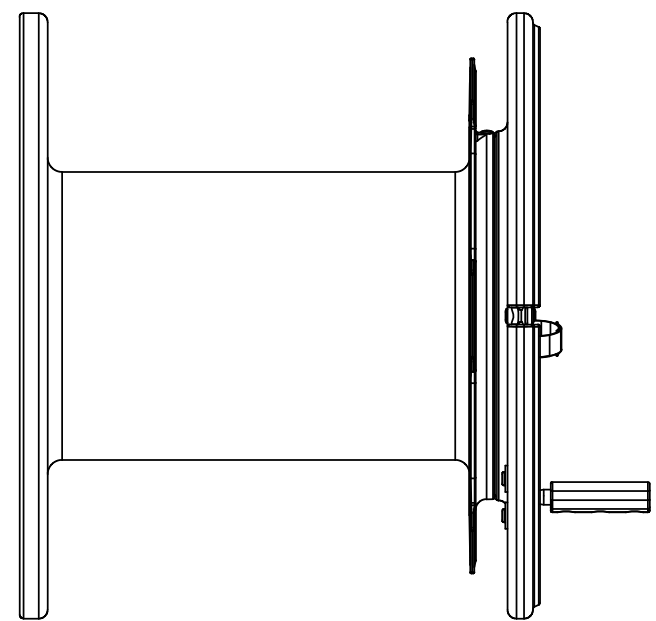
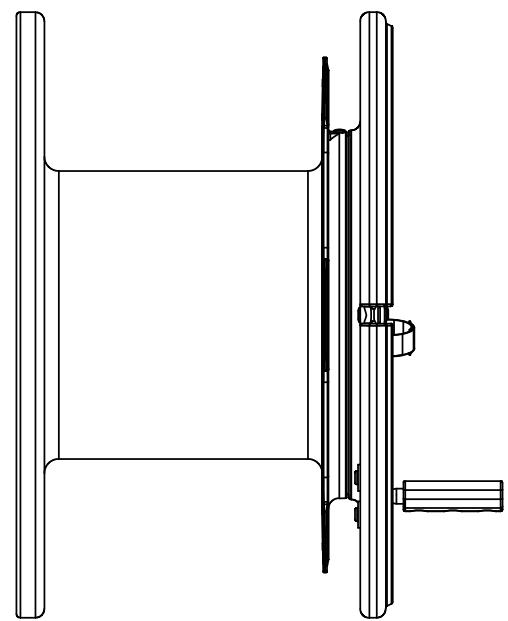

TABLE 1				
REEL SIZE	DIM "A"	DIM "B"	DIM Ø "C"	WEIGHT (LBS) MAX
ARES-300	7.76	5.00	8.0	10.5
ARES-500	10.76	8.00		11.0
ARES-750	14.76	12.00		12.0
ARES-1000	18.76	16.00		12.5



VIEW A-A  
ARES-300, 500, 750, 1000

SIZE <b>C</b>	CAGE CODE ØYPM2	DWG NO ARES-XXXX	REV <b>B</b>
SCALE 3:8	SHEET 2 OF 3		

4

3

2

1

4

3

2

1

TABLE 2				
REEL SIZE	DIM "A"	DIM "B"	DIM Ø "C"	WEIGHT (LBS) MAX
ARES-3000	22.3	17.0	13.4	35.0

D

D

C

C

B

B

A

A

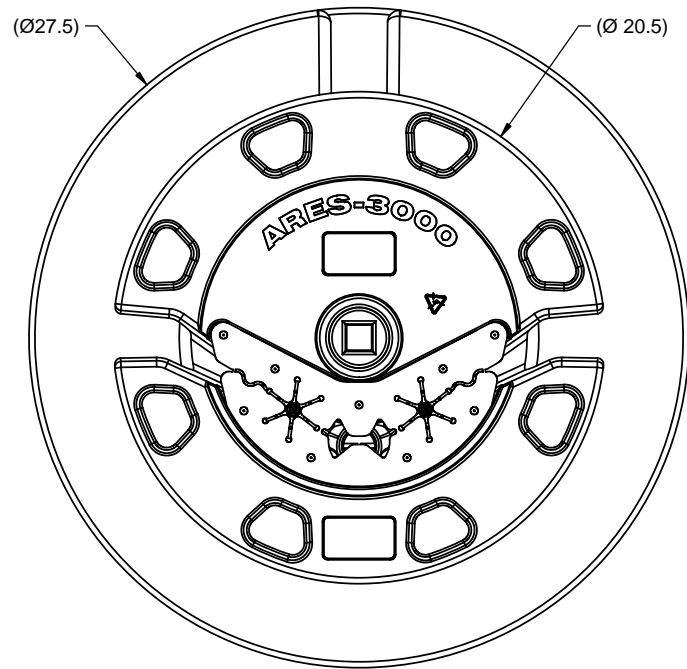
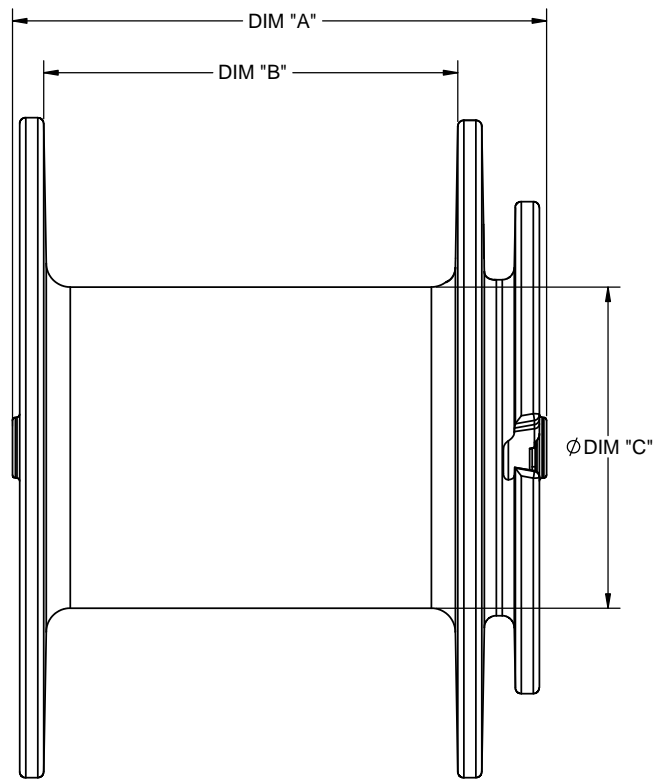

3000 METER

SIZE <b>C</b>	CAGE CODE <b>ØYPM2</b>	DWG NO <b>ARES-XXXX</b>	REV <b>B</b>
SCALE 1:4	SHEET 3 OF 3		

1

4

3

2