

4

3

2

1

NOTES:

REVISION HISTORY - ALL SHEETS ARE THE SAME REVISION			
REV	DESCRIPTION	DATE	APP
A	FORMAL RELEASE	2012/11/15	JW
B	ECN 151209-1111, XLT	2015/12/09	CJ

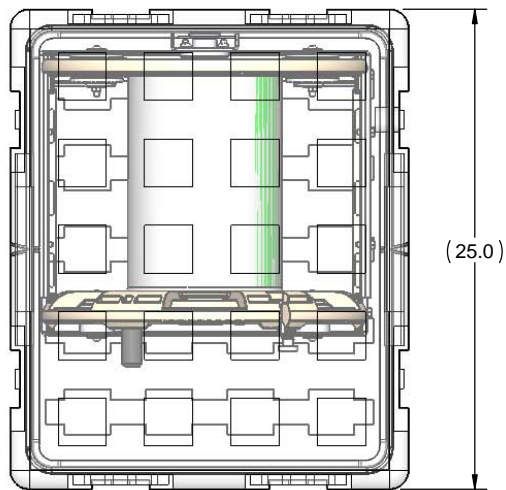

TRANSIT CASE

ARES-500L REEL FOR REF ONLY

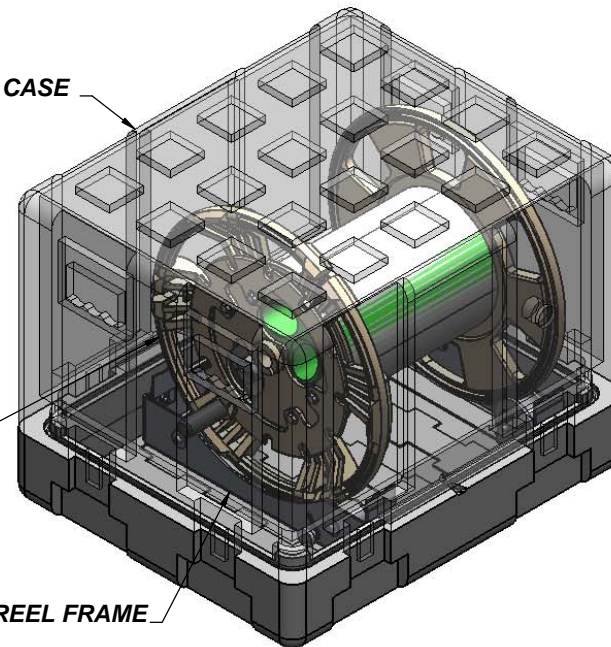

REEL FRAME

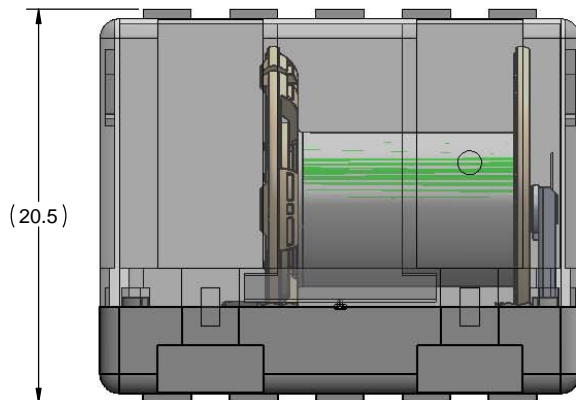
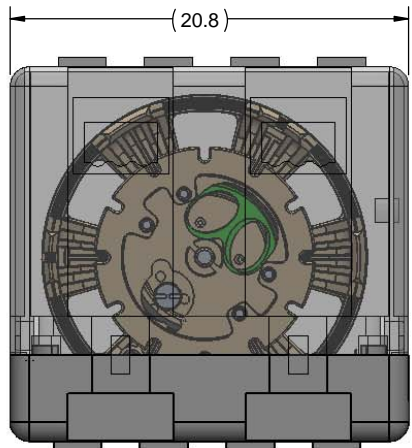

TABLE 1		
PART NO.	CASE COLOR	EGRESS
ARES-TCG	GREEN	UNSEALED
ARES-TCT	TAN	UNSEALED
ARES-TCGS	GREEN	SEALED
ARES-TCTS	TAN	SEALED

PRODUCT DRAWING

		MATERIAL	DFT RAH 10/23/2012
			CHK MH 10/23/2012
			MFG
		DRILLED HOLE DIAMETER TOLERANCE	ENG MH 10/24/2012
		$\phi .000$ TO $\phi .125$ $+0.004$ -0.001	APP JW 2012/11/15
		$\phi .251$ TO $\phi .500$ $+0.005$ -0.001	
		$\phi .126$ TO $\phi .250$ $+0.005$ -0.001	
		$\phi .501$ TO $\phi .750$ $+0.008$ -0.001	
		DO NOT SCALE DRAWING UNLESS OTHERWISE SPECIFIED DIM ARE IN INCHES	This Document contains proprietary information and such information is prohibited from disclosure to others, publication or duplication in whole or in part without written permission from Amphenol Fiber Systems International.
		INTERPRET DIM AND TOL PER ASME Y14.5-2009	Copyright © 2011 Amphenol Fiber Systems International. Nonpublished work. All rights reserved.
	ARES		
NEXT ASSY	USED ON		

TITLE			
TRANSIT CASE W/500 METER FRAME			
SIZE	CAGE CODE	DWG NO	REV
C	ØYPM2	ARES-TCX	B
SCALE	1:5	SHEET	1 OF 1

3

2

1

TOP ASSY: 137-160