

# Amphenol

Amphenol-Tuchel Electronics GmbH

Connectors, Cables and AISG cable assemblies

Steckverbinder, Kabel und AISG Kabelkonfektionierungen



- Salt mist resistant / Salznebelbeständig
  - Protection degree IP67 / Schutzart IP67
  - UV resistant / UV - Beständig
  - Halogen free / Halogenfrei
- Easy and reliable cable assembly on site by using crimp contacts / Einfache und zuverlässige Vorort-Kabelkonfektionierung durch den Einsatz von Crimpkontakten

**Amphenol** - market leader for multipole connectors according to the IEC 60130-9

**Amphenol** - Marktführender Anbieter für mehrpolige Steckverbinder nach IEC 60130-9

Application: RET (Remote Electrical Tilt)  
TMA (Tower Mounted Amplifier)

## Male Cable Connector Kabelstecker / Stifte

Ø Cable  
Ø Kabel

Part no.  
Artikel-Nr.

Packing unit  
Verpackungseinheit

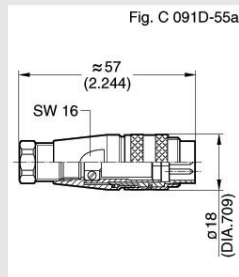

4-6 mm    **C091 11H008 810 2**    50

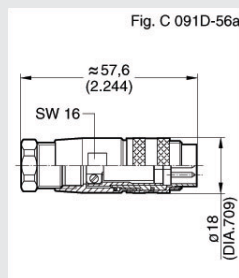

6-8 mm    **C091 11H008 811 2**    50

## Female Cable Connector Kabeldose / Buchsen

Ø Cable  
Ø Kabel

Part no.  
Artikel-Nr.

Packing unit  
Verpackungseinheit

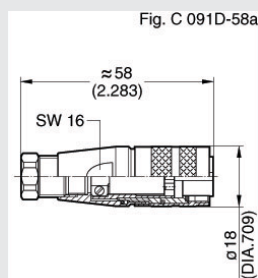

4-6 mm    **C091 11D008 810 2**    50

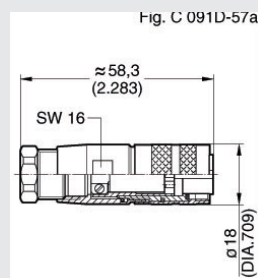

6-8 mm    **C091 11D008 811 2**    50

## Contacts / Kontakte Male / Stift

Part no.  
Artikel-Nr.

Packing unit  
Verpackungseinheit



0.14 - 0.5 mm<sup>2</sup>  
0.5 - 0.75 mm<sup>2</sup>

VN01 015 0046 1  
VN01 015 0047 1

100

## Contacts / Kontakte Female / Buchse



0.14 - 0.5 mm<sup>2</sup>  
0.5 - 0.75 mm<sup>2</sup>

VN02 015 0046 1  
VN02 015 0047 1

100

## Dust cap Staubschutzkappe

Part no.  
Artikel-Nr.

Packing unit  
Verpackungseinheit



N 08016 000 5

Dust cover for male cable connectors  
Staubschutzkappe für Kabelstecker

100



N 08016 000 7

Dust cover for female cable connectors  
Staubschutzkappe für Kabeldose

100

## Tools / Werkzeuge

### Handcrimp tool / Crimpzange



Part no.  
Artikel-Nr.

Packing unit  
Verpackungseinheit

TA 0000

1

### Locator / Kontaktaufnahme



TA 0002 091 0001

1

### Crimping dies / Crimpbacken



TA 0000 502

1

### Removal tool / Kontaktlösewerkzeug



FH 0200 911

1

### Spanner / Montagewerkzeug



FH 0300-091

1

# Cable Assemblies Kabelkonfektionierungen



Part Number	Sheath	Length in meter
CA 091 60 2000 150	PUR	150
CA 091 60 2000 125	PUR	125
CA 091 60 2000 105	PUR	105
CA 091 60 2000 100	PUR	100
CA 091 60 2000 095	PUR	95
CA 091 60 2000 090	PUR	90
CA 091 60 2000 085	PUR	85
CA 091 60 2000 080	PUR	80
CA 091 60 2000 075	PUR	75
CA 091 60 2000 070	PUR	70
CA 091 60 2000 065	PUR	65
CA 091 60 2000 060	PUR	60
CA 091 60 2000 055	PUR	55
CA 091 60 2000 050	PUR	50
CA 091 60 2000 045	PUR	45
CA 091 60 2000 040	PUR	40
CA 091 60 2000 035	PUR	35
CA 091 60 2000 030	PUR	30
CA 091 60 2000 025	PUR	25
CA 091 60 2000 020	PUR	20
CA 091 60 2000 019	PUR	19
CA 091 60 2000 018	PUR	18
CA 091 60 2000 017	PUR	17
CA 091 60 2000 016	PUR	16
CA 091 60 2000 015	PUR	15
CA 091 60 2000 014	PUR	14
CA 091 60 2000 013	PUR	13
CA 091 60 2000 012	PUR	12
CA 091 60 2000 011	PUR	11
CA 091 60 2000 010	PUR	10
CA 091 60 2000 009	PUR	9
CA 091 60 2000 008	PUR	8
CA 091 60 2000 007	PUR	7
CA 091 60 2000 006	PUR	6
CA 091 60 2000 005	PUR	5
CA 091 60 2000 004	PUR	4
CA 091 60 2000 003	PUR	3
CA 091 60 2000 002	PUR	2
CA 091 60 2000 001	PUR	1
CA 091 60 2000 960	PUR	0,6
CA 091 60 2000 950	PUR	0,5

## Configuration of terminals

C091 female cable connector contact cavity	Color of wire	C091 male cable connector contact cavity	Wire gauge	Function
Nr. 1	blue	Nr. 1	0,75mm <sup>2</sup> (approx. 18AWG)	+ 12V nominal
Nr. 2	not connected	Nr. 2	not connected	not used
Nr. 3	white	Nr. 3	0,25mm <sup>2</sup> (approx. 24AWG)	RS485 A
Nr. 4	green	Nr. 4	0,75mm <sup>2</sup> (approx. 18AWG)	RS485 GND
Nr. 5	brown	Nr. 5	0,25mm <sup>2</sup> (approx. 24AWG)	RS485 B
Nr. 6	red	Nr. 6	0,75mm <sup>2</sup> (approx. 18AWG)	+ 24V nominal
Nr. 7	black	Nr. 7	0,75mm <sup>2</sup> (approx. 18AWG)	DC return
Nr. 8	not connected	Nr. 8	not connected	not used

## Cable / Kabel

Part no.  
Artikel-Nr.

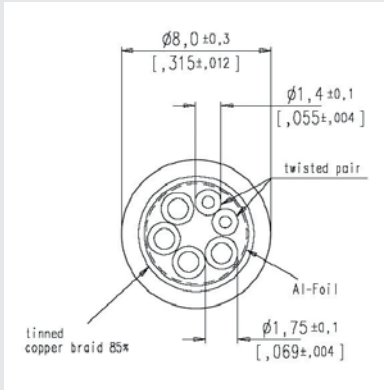

1 x 2 x 0,25 + 4 x 0,75 mm<sup>2</sup>

N 51 091 0002 Z

## Assembly Instruction / Montageanleitung

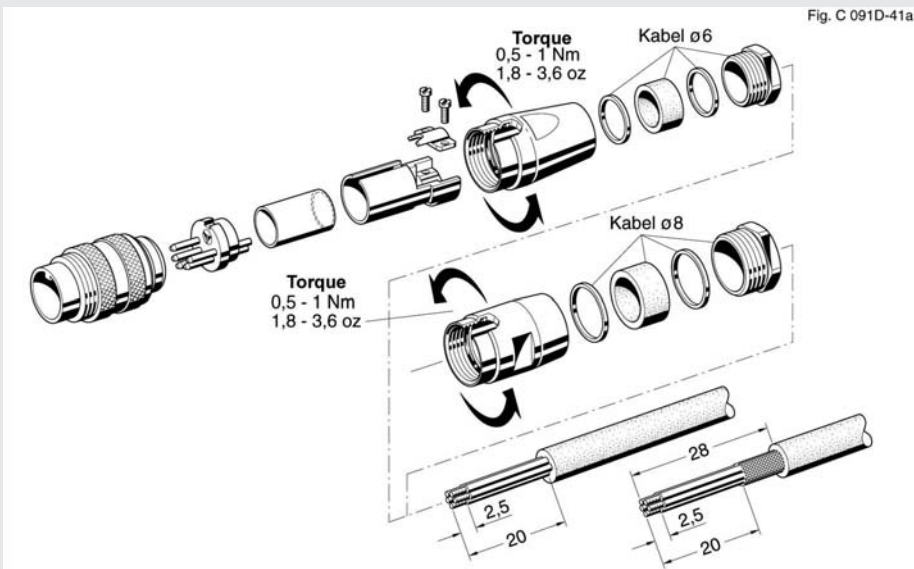

In the case of shielded cables, fold the braid over the mantle.  
Bei geschirmten Kabeln ist der Schirm auf den Außenmantel umzuschlagen.

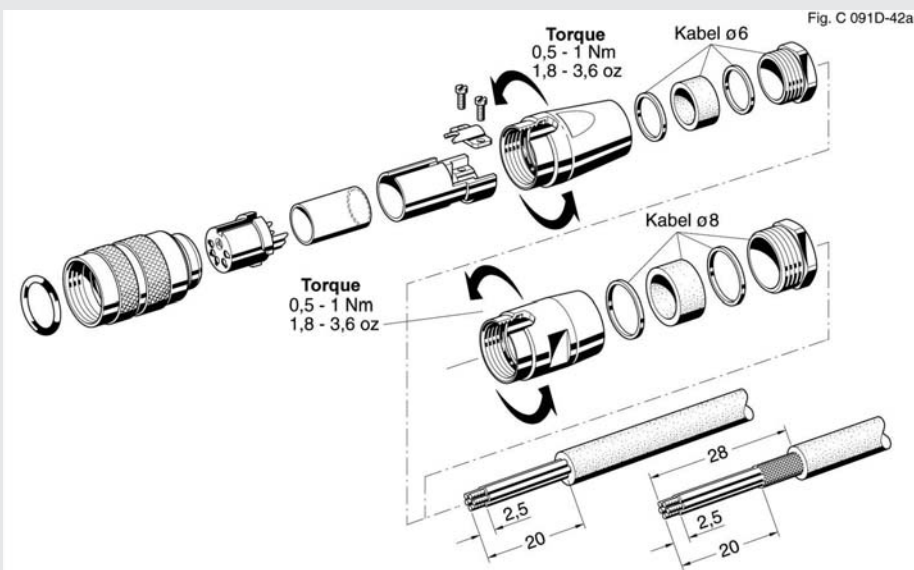

## Amphenol

Amphenol Tuchel Electronics GmbH  
August-Häusser-Str. 10 • 74080 Heilbronn • Germany  
Phone +49 (0) 7131/929-0 • Fax +49 (0) 7131/929 486  
[www.amphenol.info](http://www.amphenol.info)

For further technical characteristics please refer our catalogue C091 A/B/D

Weitere technische Daten finden sie in unserem Katalog C091 A/B/D