

# Amphenol Industrial

## EV Market Introduction & Application

# Content

- EV Market Overview
- BEV & Super Charge
- Battery Swapping
- The Electrification of Mobility
- Hydrogen Fuel Cell Vehicle
- Products
- Applications

## ➤ Electric vehicles and the environment

**Greenhouse Gas Pollution** (Light duty vehicles only)  
(Billion/ tonnes CO<sub>2</sub>-equivalent/year)

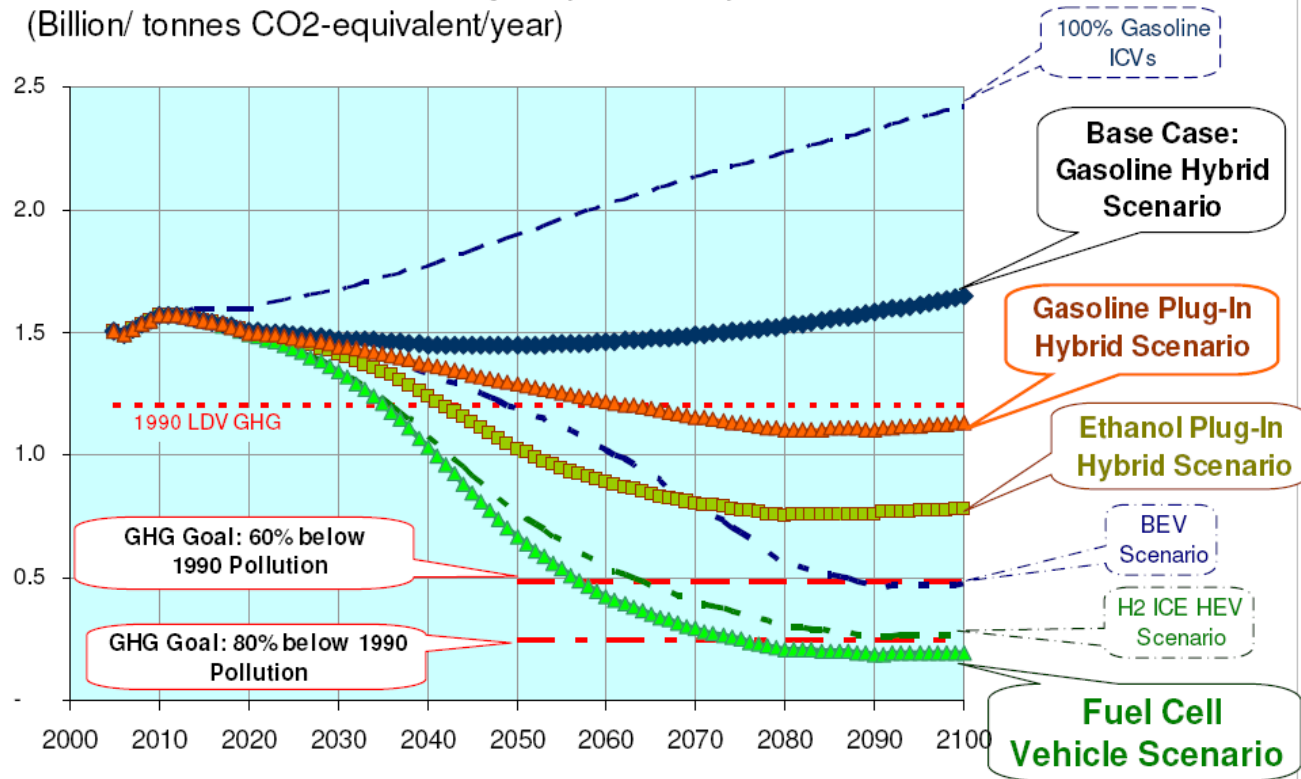

# ➤ EV MARKETS AND FORECAST

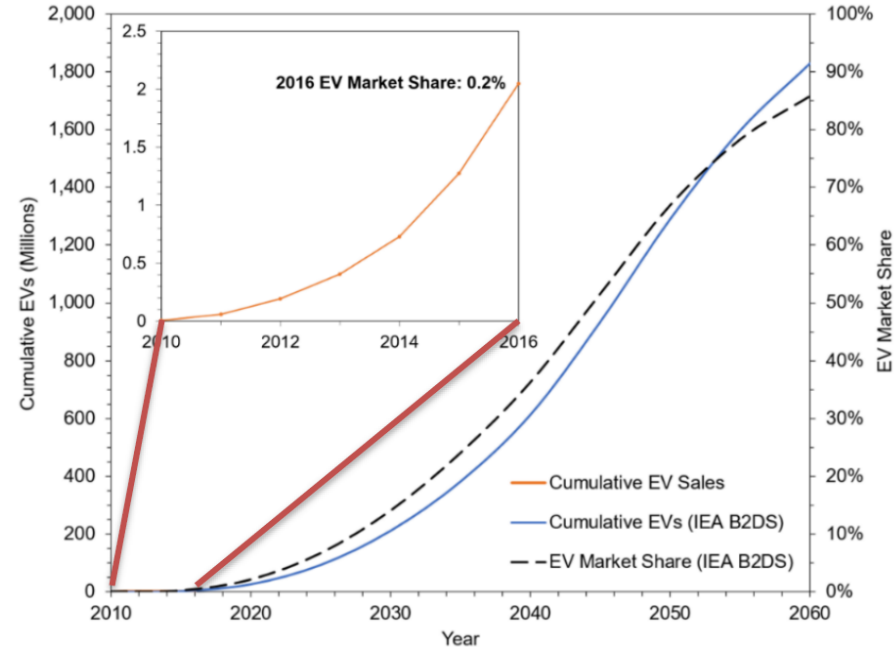
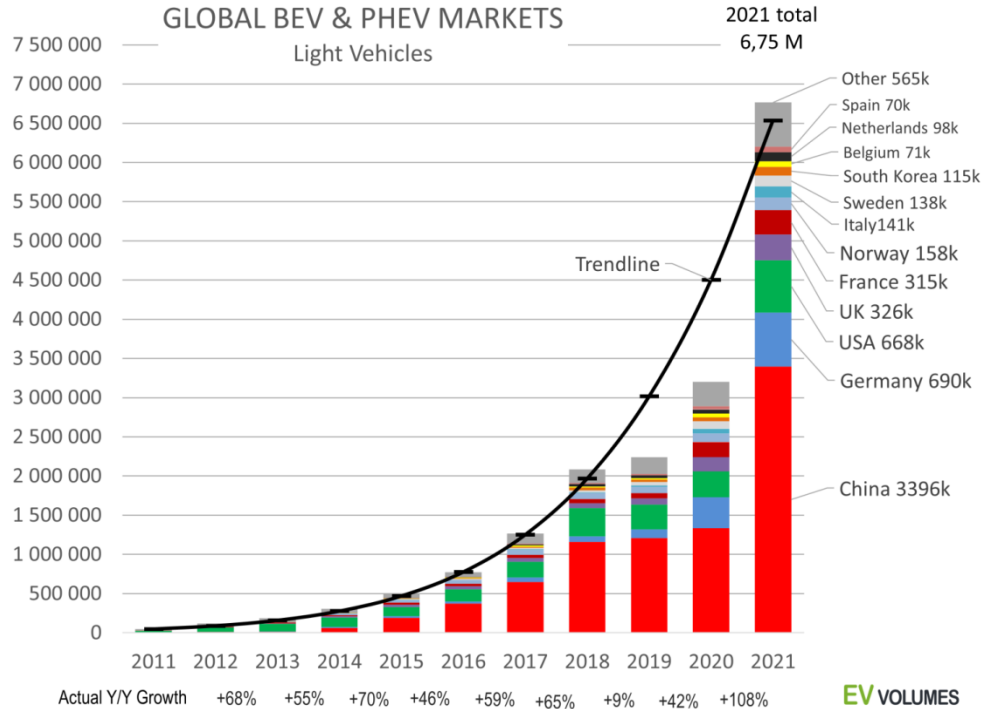

## ➤ User focus

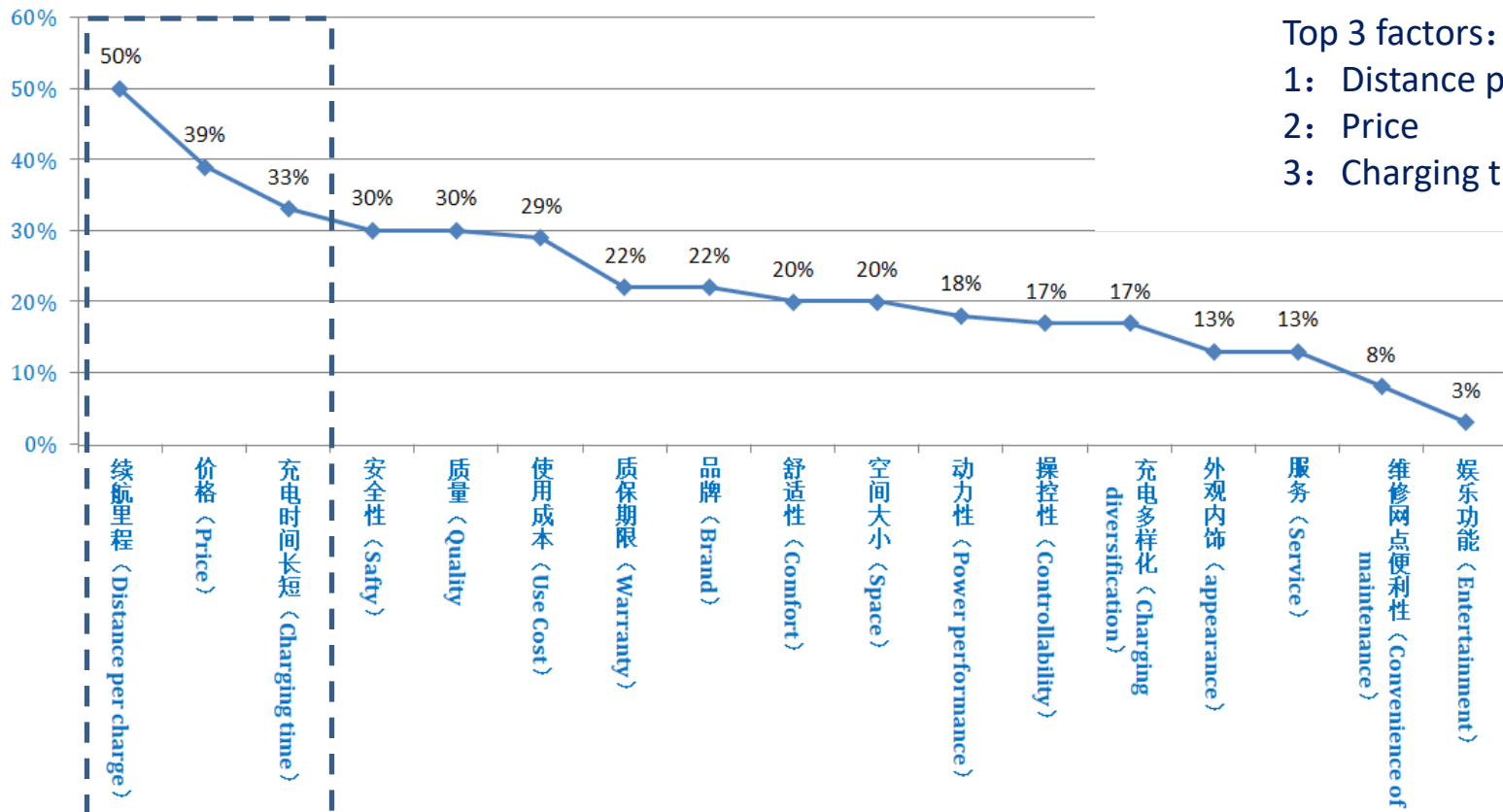

Top 3 factors:

1: Distance per charge

2: Price

3: Charging time

# ➤ New energy charge

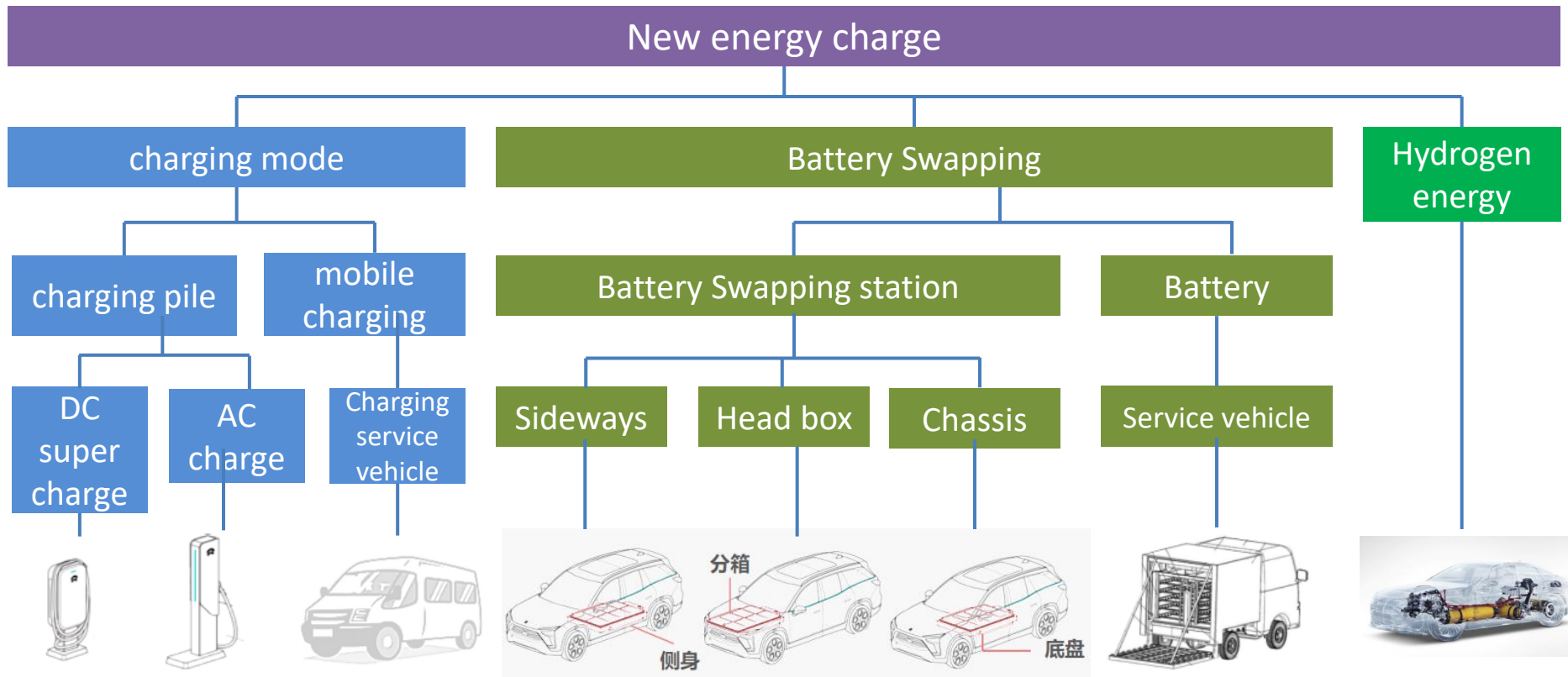

## ➤ Distance per charge

- New Battery Technology
- Higher power density
- Higher charging and discharging speed



- Hydrogen cell

- Higher Voltage platform-800V
- Super charge



- Battery Swapping

➤ BEV/PHEV/FCV





# BEV & SUPER CHARGE

## ➤ BEV/Super charge

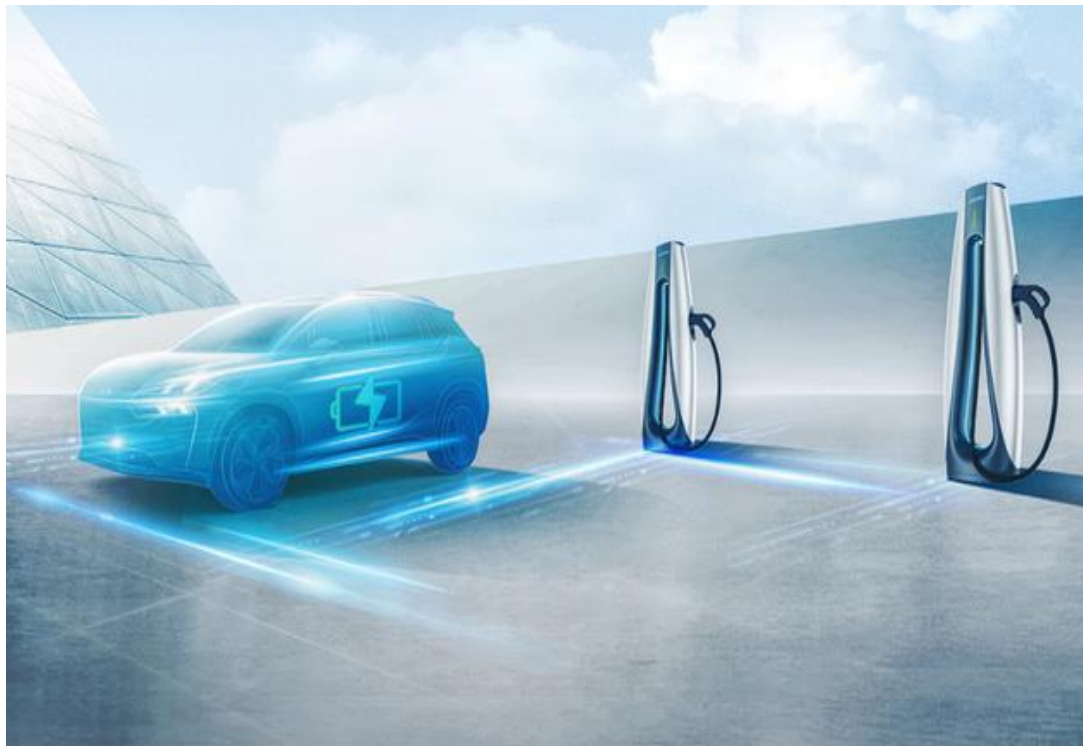

- 800V connector



- Charge Gun





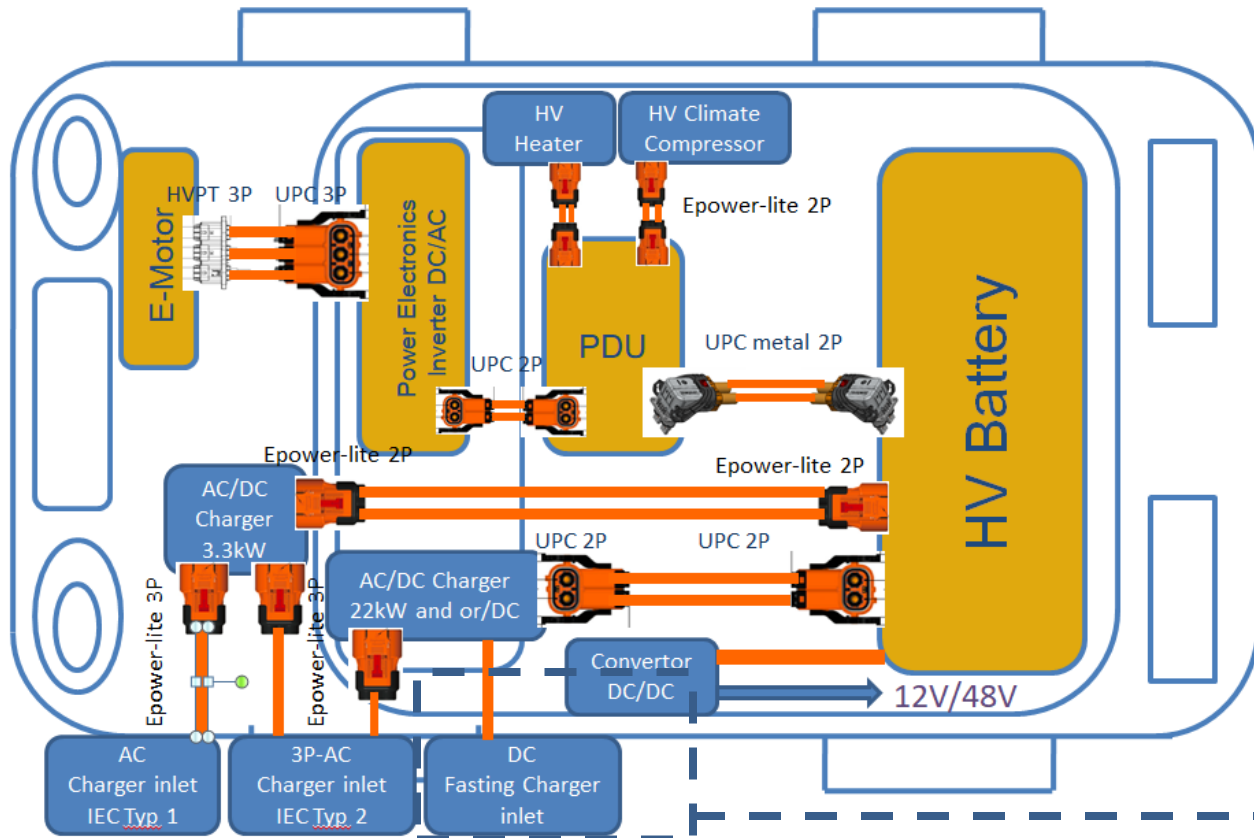



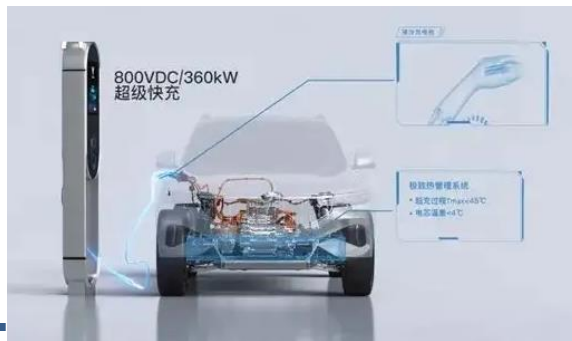
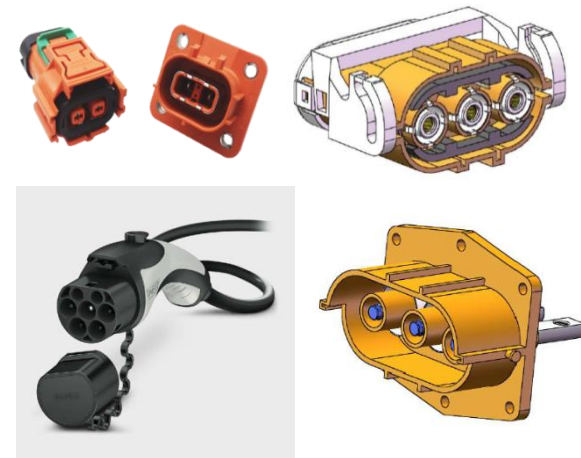



## ➤ BEV/Super charge application



- 800V connector



## ➤ Charge Gun Type

	USA Type1	Euro Type 2	China	Japan
AC	 SAE J1772/IEC 62193-2	 IEC 62193-2	 GB/T 20234.2	 IEC 62193-2
DC	 IEC 62193-2	 IEC 62193-3	 GB/T 20234.3	 CHAdeMO
Combi nation Type	 SAE J1772 /IEC 62193-3	 IEC 62193-3		



Tesla

# ➤ Liquid Cooled Charge Gun

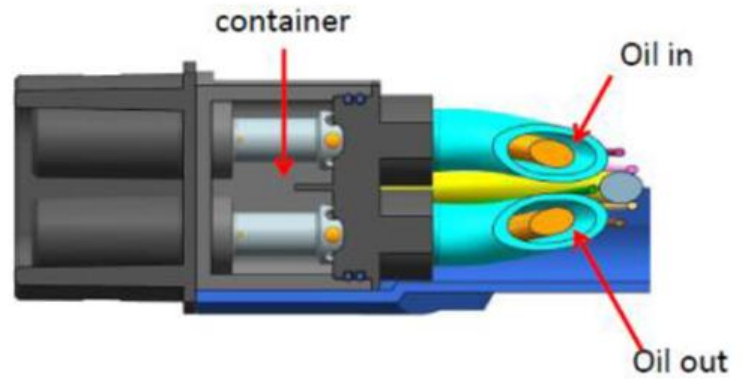
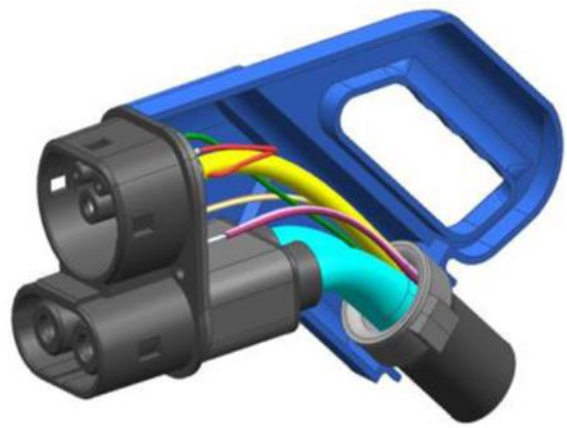
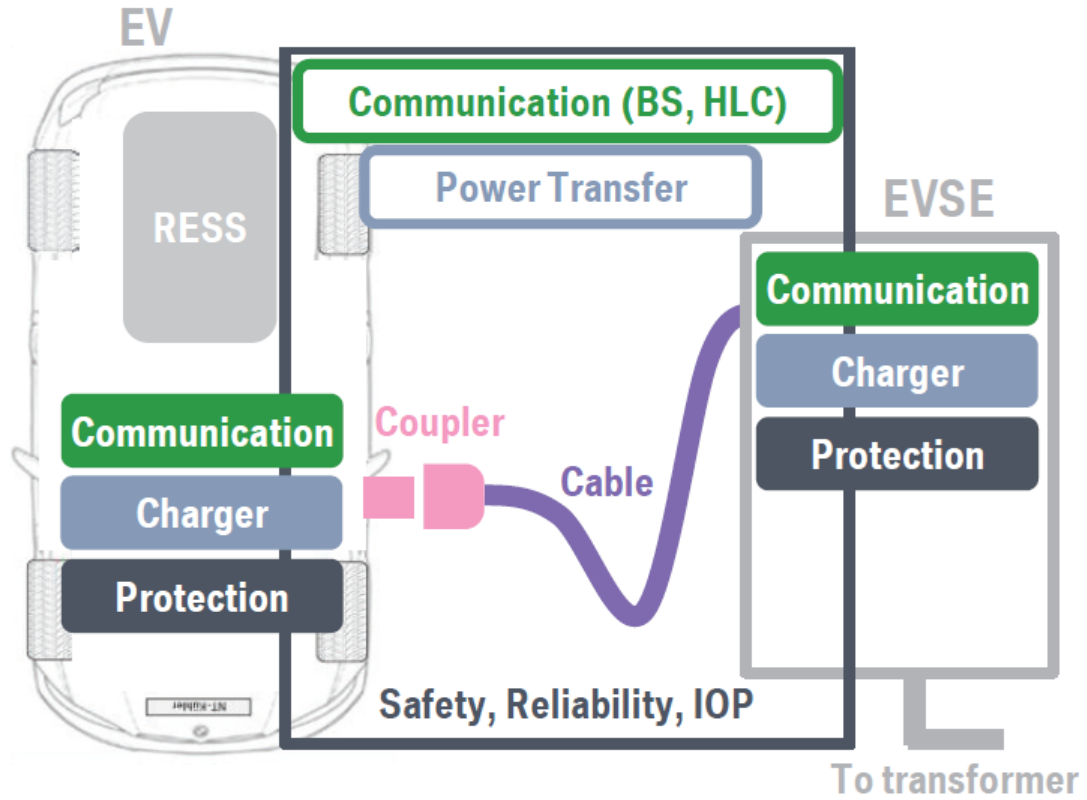

# Battery Swapping

## ➤ Marketing forecast

- Till 2025Y, total battery swapping station up to 30000+, Overall market up to hundred billion+

	换电汽车市场预测						换电站市场预测														
	销售量 (万辆)			保有量 (万辆)			换电站数量 (万座)						换电设备 (亿元)			用电市场 (亿元)			运营市场 (亿元)		
							供给端预测 <sup>注释1</sup>			需求端预测 <sup>注释2</sup>											
	2021	2025E	CA GR	2021	2025E	CA GR	2021	2025E	CA GR	2021	2025E	CA GR	2021	2025E	CA GR	2021	2025E	CA GR	2021	2025E	CA GR
整体市场	16	192	86%	25	415	102%	0.14	3.4	122%	0.14	3.1	117%	45	1012	118%	16	355	118%	117	616	90%
乘用车市场	15	176	85%	22.4	376	102%				0.08	1.5	112%	19	376	112%	6.3	127	112%	92.8	262	85%
商用车市场	1.1	16	98%	2.6	36.1	96%				0.07	1.6	122%	26	636	122%	9.5	229	122%	24.5	356	95%

## ➤ Battery Swapping heavy trucks market forecast(2021-2030)

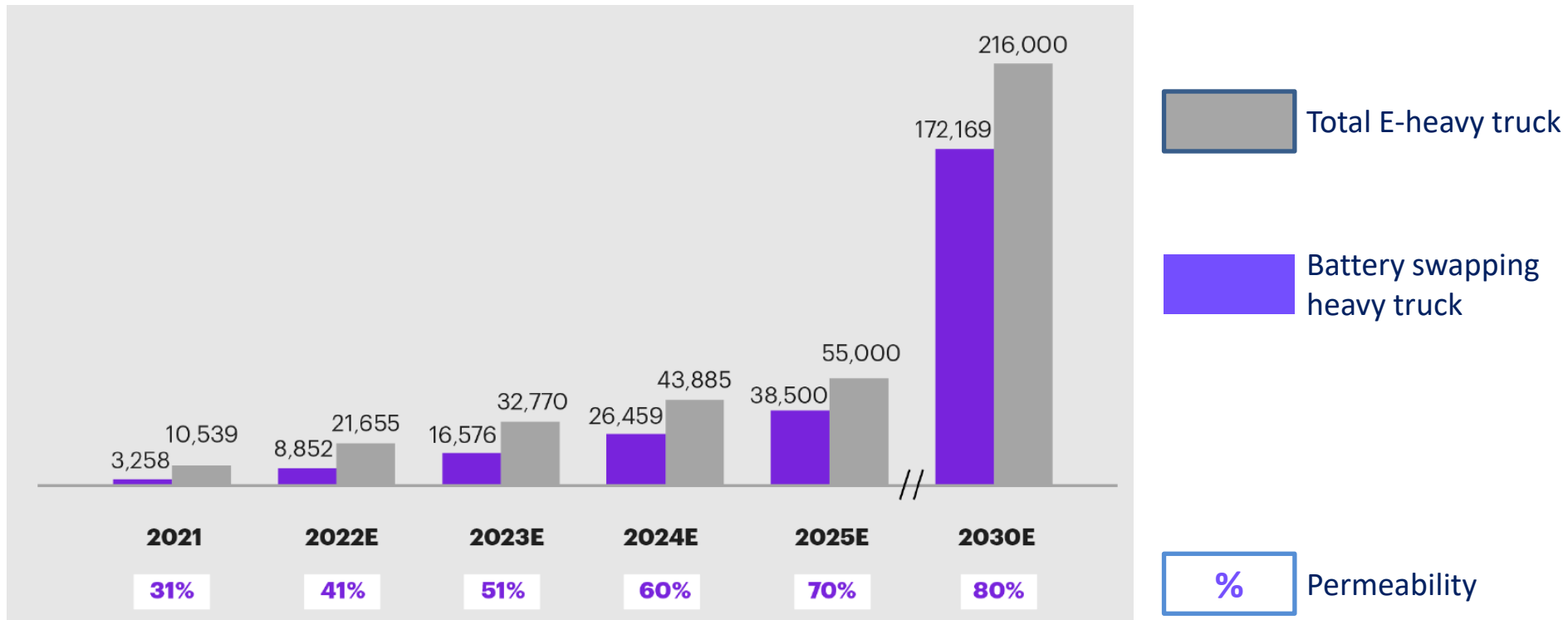



## ➤ Battery Swapping Station

- Normally it takes about 10mins to finish battery swapping
- The installation position, size and interface of the battery box are unified
- Higher cost to build the Battery Swapping Station
- Need government policy to support

### 换电站站内结构图

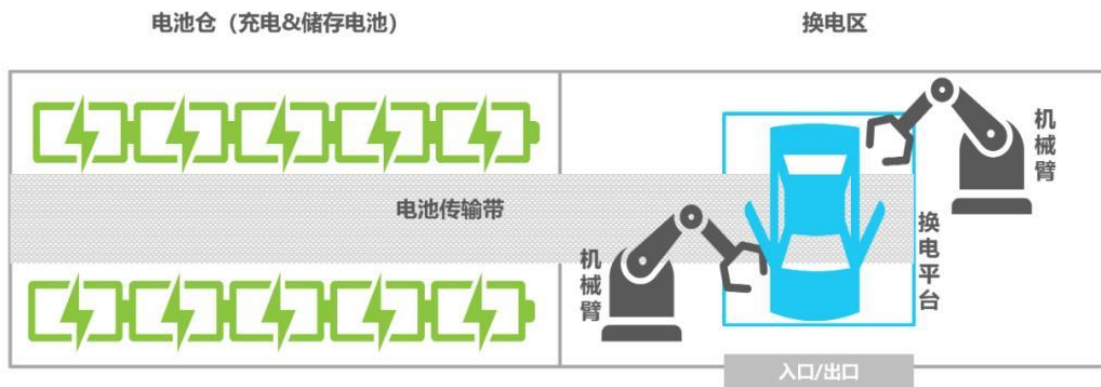

# ➤ CATL-Battery Swapping



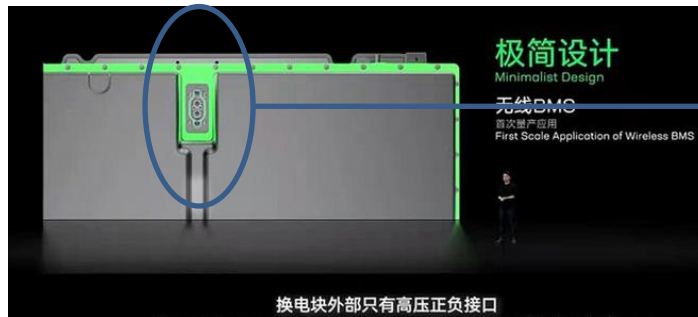
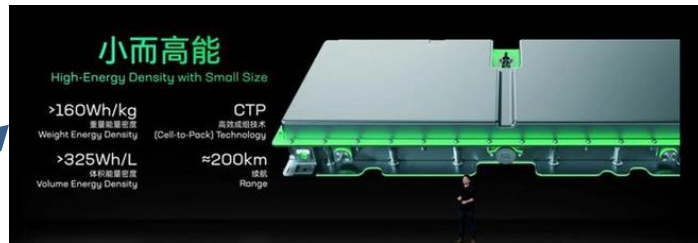

Total 48pcs battery

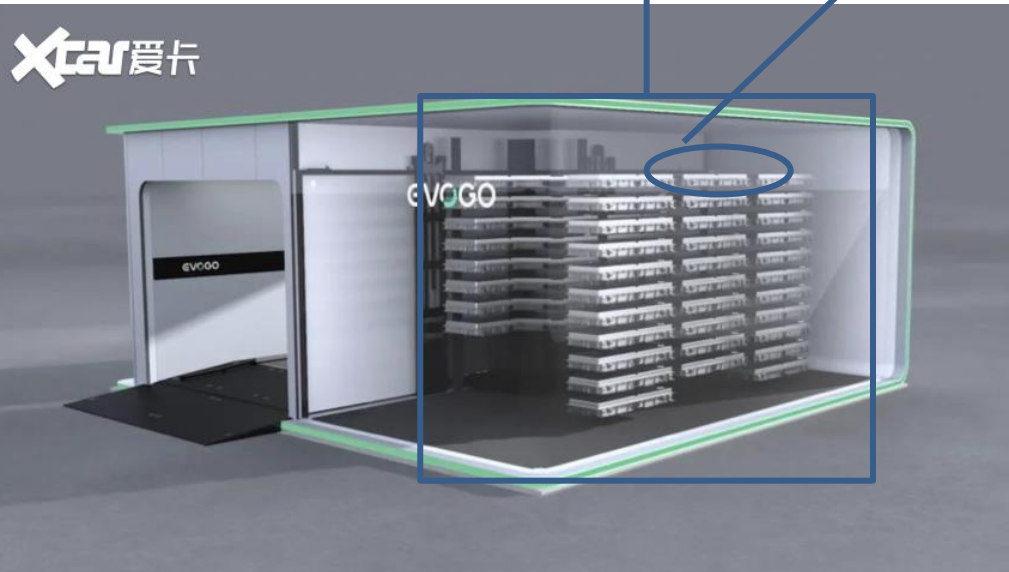
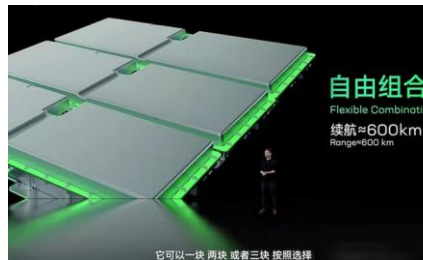

Connector



## ➤ Battery Swapping Connector

Application	PIC
后备箱 Trunk	
底盘 chassis	
侧身 Sideways	
立体车库 stereo garage	

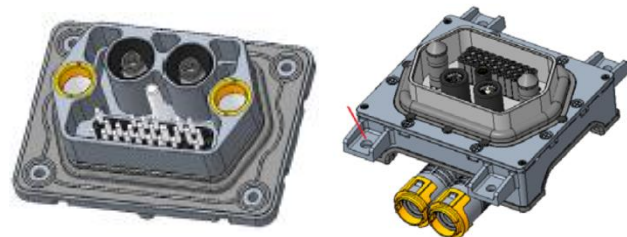

# The Electrification of Mobility

## E-MOBILITY

## APPLICATIONS

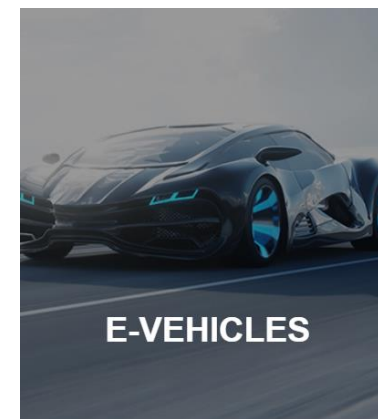
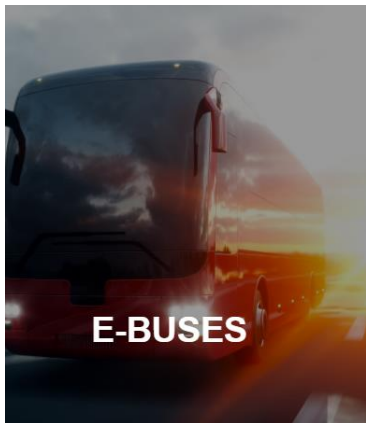

# Hydrogen Fuel Cell Vehicle

## ➤ HOW FCEV WORKS

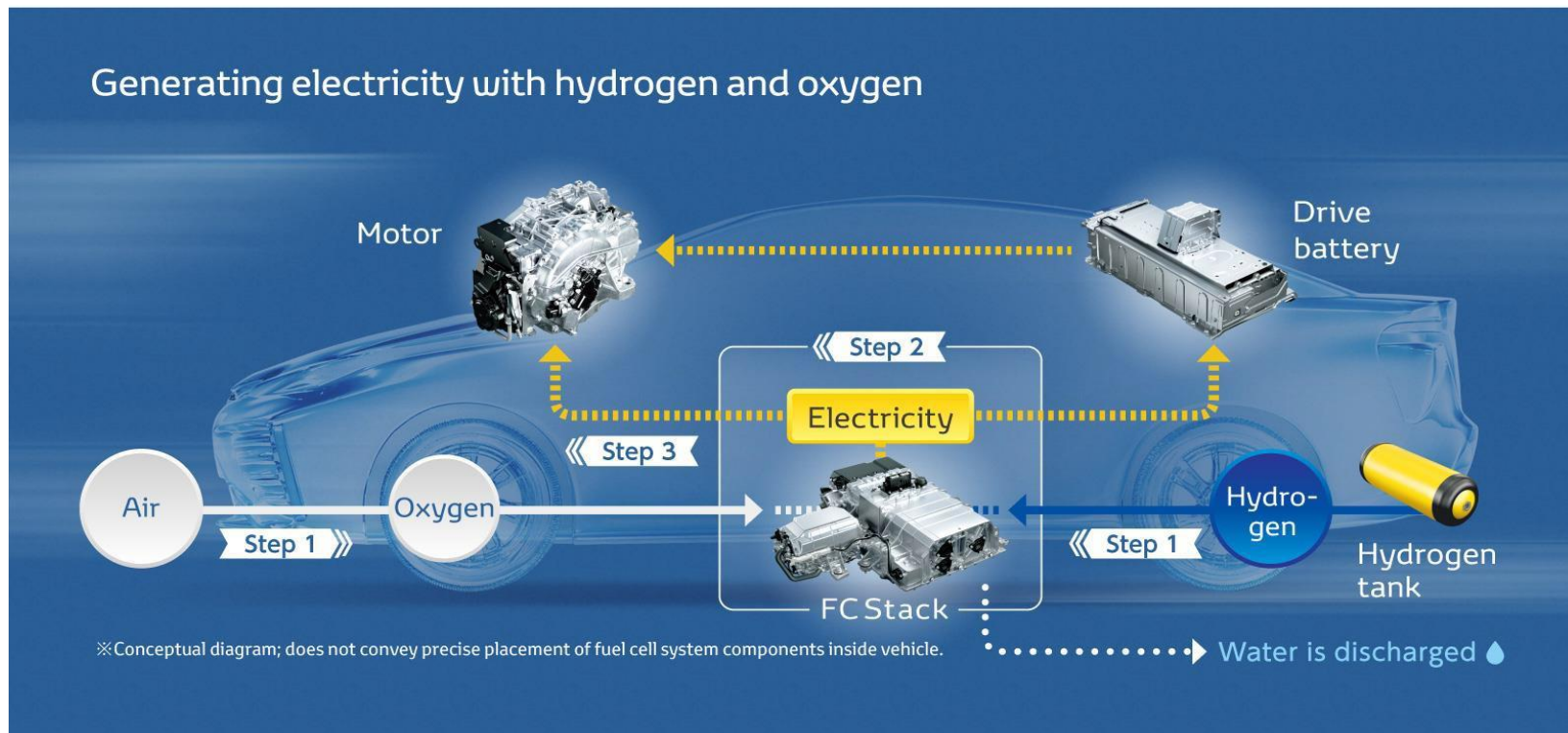

➤ FCV application



STACK



AIR-Compressor

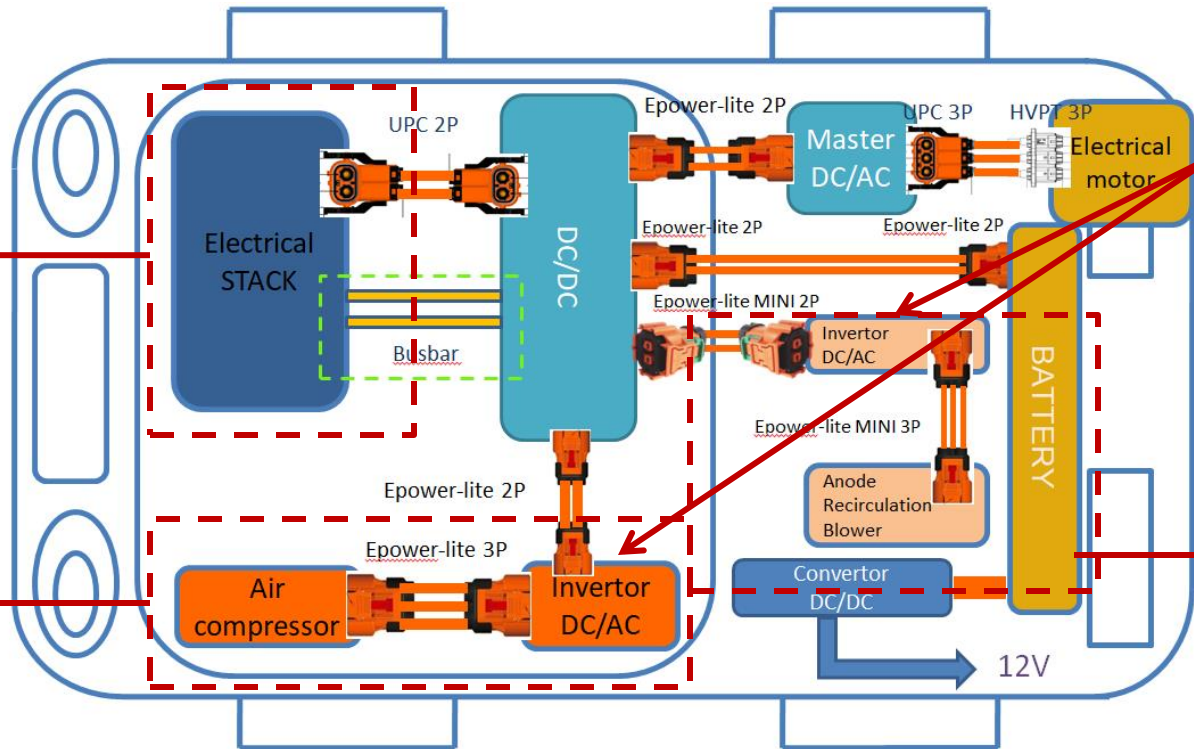

INVERTOR



Anode Recirculation  
Blower



# FCV application

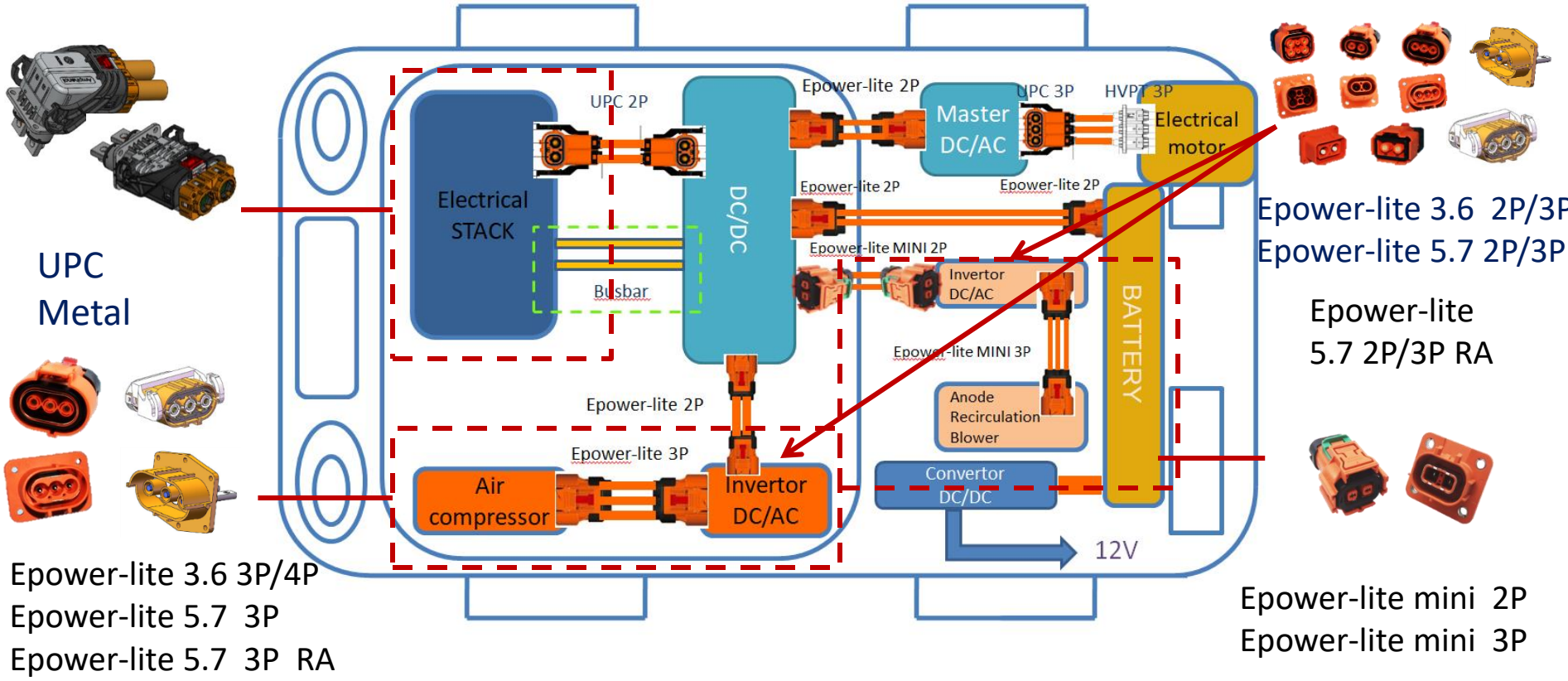

Epower-lite 3.6 3P/4P  
 Epower-lite 5.7 3P  
 Epower-lite 5.7 3P RA

Epower-lite 3.6 2P/3P  
 Epower-lite 5.7 2P/3P

Epower-lite  
 5.7 2P/3P RA

Epower-lite mini 2P  
 Epower-lite mini 3P

# Products

24

## UPC Series



### Features and Benefits

- Compact design for space considerations with Evs
- Touch proof (UL 2251), EMI (60db/100M), HVIL
- Wide amperage range (200A-400A)
- Plastic shell, light weight, UL 94V-0
- Waterproof IP67 according to EN 60068-1

### Technical Info.

Current Rating: 200A, 400A

Voltage Rating: 1000 V AC

Operating Temperatures: -40°C to 125°C

Applicable Cable: 200A: 25mm<sup>2</sup>-50mm<sup>2</sup>

400A: 70mm<sup>2</sup>-95mm<sup>2</sup>

Durability: 500+ mating cycles

### Application

Automotive/HEV/EV/Energy storage

25

## ePower-Lite Series



### Features and Benefits

- Compact design for space considerations with Evs
- Touch proof (IEC 60529), EMI (60db/100M), HVIL
- Secondary locking feature
- Plastic shell, light weight, flammability: UL 94V-0
- Waterproof IP67 according to EN 60068-1

### Technical Info.

Current Rating: 70A

Voltage Rating: 1000 V AC

Operating Temperatures: -40°C to 125°C

Applicable Cable: 2.5mm<sup>2</sup>, 4mm<sup>2</sup>, 6mm<sup>2</sup>, 10mm<sup>2</sup>

Durability: 500+ mating cycles

### Application

Automotive/HEV/EV/Energy storage

**PRODUCT ROADMAP**

**Product**

**Product Cable Range Plan**

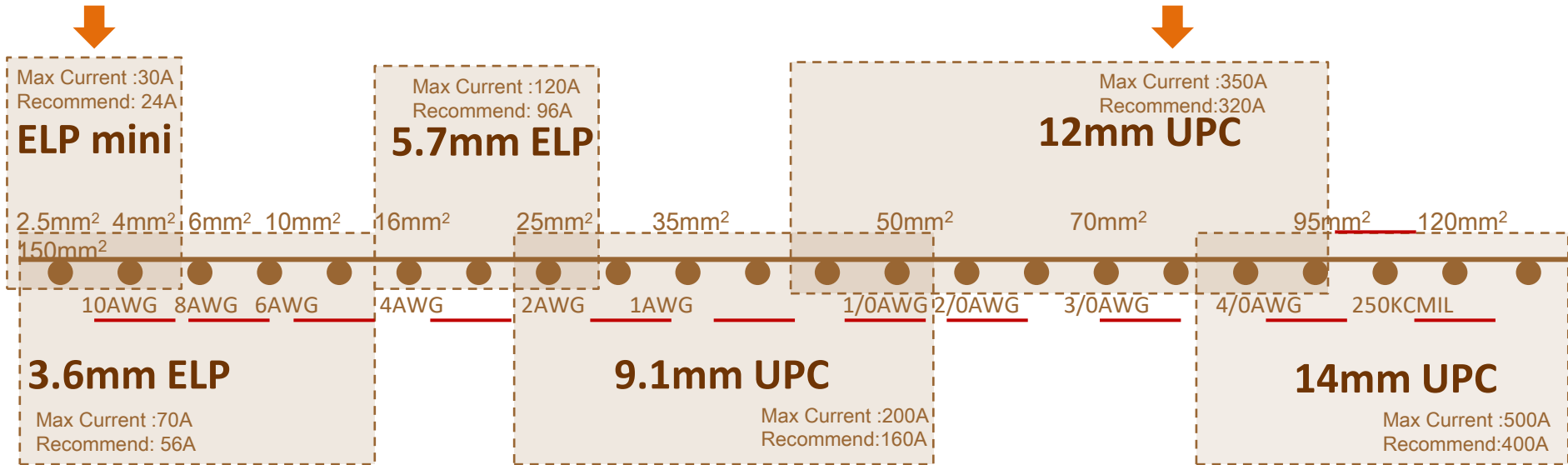

**ePower-Lite and UPC cable range**

- Recommend current follow standard IEC 60512-5-2/page4/item2.3
- Derating curve follow factor 0.8

26

## SurLok Plus Series



### Features and Benefits

- Quick lock and press-to-release design
- Touch proof, EMI version available
- 360° rotating plug
- Compact robust design
- Waterproof IP67 according to EN 60068-1

### Technical Info.

Current Rating: 100A-350A

Voltage Rating: 1000 V AC

Operating Temperatures range: -40°C to 125°C

Applicable Cable: 2.5mm<sup>2</sup>, 4mm<sup>2</sup>, 6mm<sup>2</sup>, 10mm<sup>2</sup>

Various Termination Options: Thread, Crimp, Busbar

### Application

Automotive/HEV/EV/Energy storage

27

## ePower Series



### Features and Benefits

- IP2X on pin and socket
- Two HVIL circuits
- Excellent vibration resistance
- Waterproof IP67 according to EN 60068-1
- Integrated EMI shielding

### Technical Info.

Current Rating: 200A, 400A, 700A

Voltage Rating: 1000 V AC

Operating Temperatures: -40°C to 125°C

Applicable Cable: 25mm<sup>2</sup>-95mm<sup>2</sup>

Various termination options: Lug, Crimp, Busbar

### Application

Power converters, Hybrid electric vehicles,  
Heavy equipment electrification, Starter  
generators

## ➤ Eaxtron

- Voltage: 24V/36V/48V/72V/80V/96V  
Voltage Keying - offer keys for Dry-Cell, Wet-Cell, and Universal applications coded for 24/36/48/72/80 and 96 volts DC applications.
- Current: mainly 80A/160A/320A
- Safety Agency Approvals - UL, CSA
- Meets DIN 43589-1

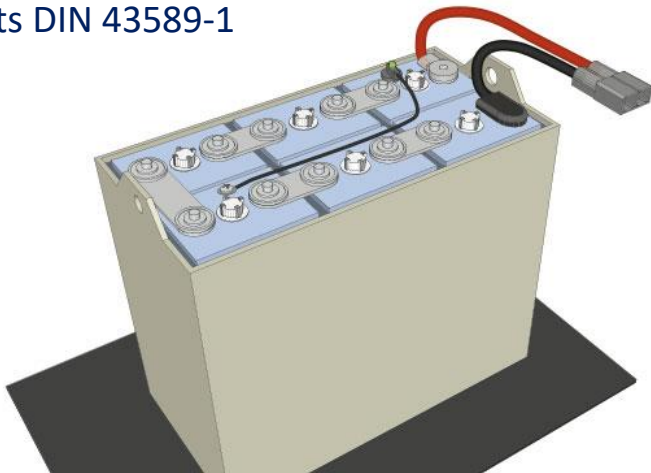



# 4

## GT Series



### Features and Benefits

- Reverse bayonet locking and compatible with VG95234 connector
- High shock and vibration, 2000 mating cycles
- Quick positive coupling
- EN45545-2 approved/ UL recognized
- IP67-IP69K in mated condition according to EN 60068-1
- RoHS & Reach compliant with proper plating

### Technical Info.

Current Rating: 13A ~ 150A (13A ~ 245A at 20°C)  
Current Rating with RADSOK Contacts: up to 250A (300A at 20°C)  
Voltage Rating: 200V ~3000V AC  
Operating Temperatures: -55°C to 125°C (up to 200°C with Viton inserts)  
Applicable Cable: 4/0-20AWG (100-0.5mm<sup>2</sup>)  
Contacts Plating: Silver or gold over nickel

### Application

Rolling stock, Electric vehicle, Servo motor, Factory Automachine/Robotics, Machine tools, Heavy equipment

## 7

## PT Series



## Features and Benefits

- Commercial version for MIL-DTL-26482 Series I
- 1/4 Turn mating, bayonet coupling
- Good shock and vibration resistance
- IP67 in mated condition according to EN 60068-1
- Variety of shell styles and shell
- RoHS&Reach compliant with proper platings

## Technical Info.

Current Rating: 7.5A ~ 23A (10A ~ 41A at 20°C)

Voltage Rating: 600V ~1000V AC

Operating Temperatures: -55°C to 125°C

Applicable Cable: 10-22AWG (5-0.3mm<sup>2</sup>)

Contacts Plating: Silver or gold over nickel

## Application

Factory Automation, Geophysical, Servo motor,  
Machine tools, Traffic control

# Applications

# Application

Application: Battery System

Product: UPC

Lock: Secondary locking

Shell: Plastic housing

EMI: EMI shielding

HVIL: HVIL optional

Voltage: 1000V DC optional

Protection: Touch Proof

Cable: 35mm<sup>2</sup>

Current: 150A

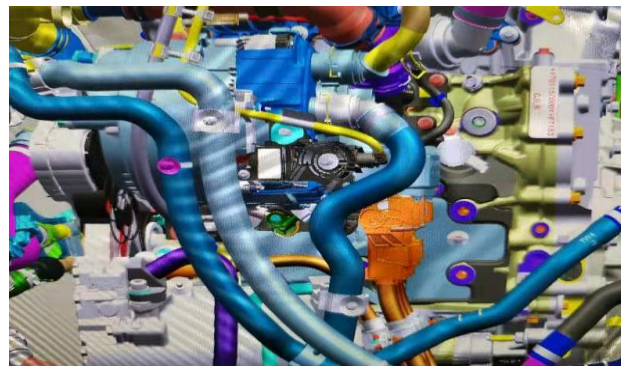

# Application

Application: FCV Compressor  
Product: 3.6mm ePower-Lite, 2,4ports

Lock: Secondary locking

Shell: Plastic housing

EMI: EMI Shielding

HVIL: HVIL optional

Voltage: 1000V DC optional

Protection: Touch Proof

Cable: 10mm<sup>2</sup>

Current: 85°C, 60A

.....



# Application

Application: FCV Compressor Controller  
Product: 3.6mm ePower-Lite, 2,3,4ports



# Application

Application: Stack Pack  
Product: UPC,2,3 ports, ePower-lite  
Location: RD in EU, Manufacture in China

Lock: Secondary Locking  
Shell: Plastic housing  
EMI: EMI Shielding  
HVIL: HVIL optional  
Voltage: 1000V DC optional  
Protection: Touch Proof  
Cable: 10~95mm<sup>2</sup>  
Current: 85°C, 80~400A

.....

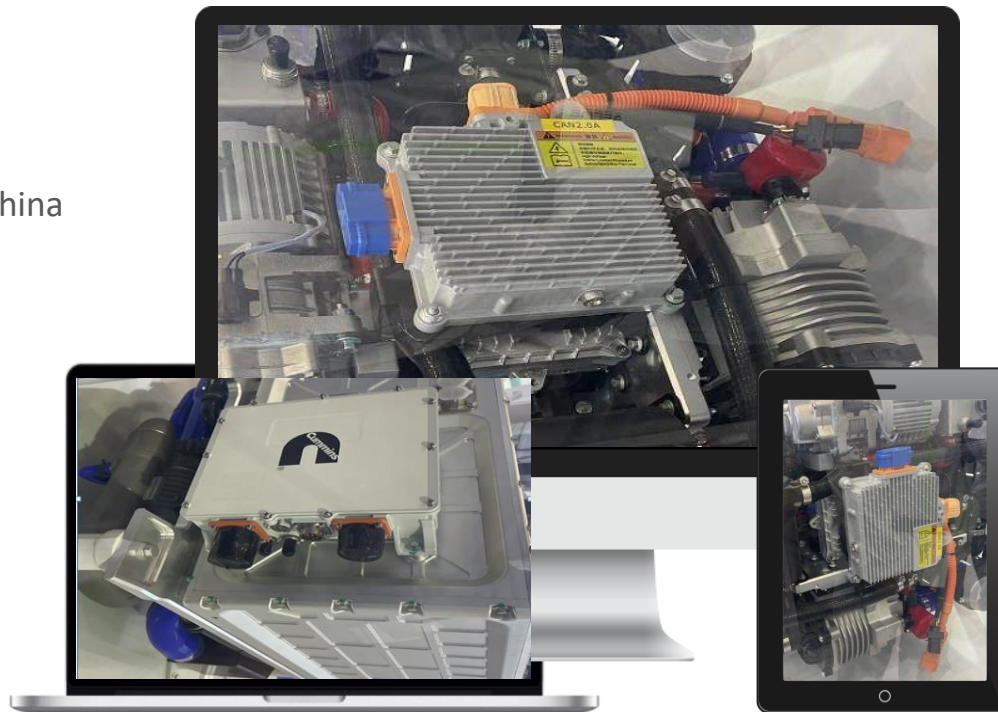



### Charging connection



### Battery connection





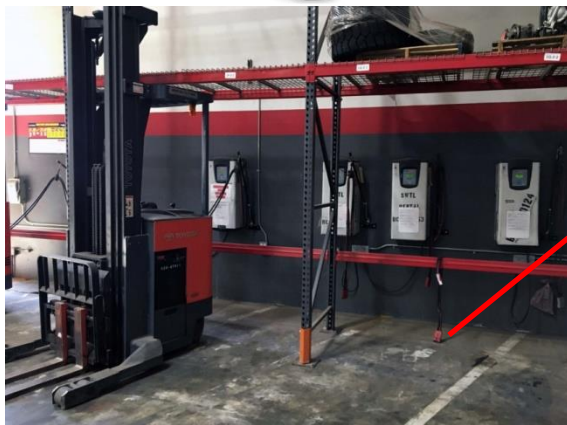
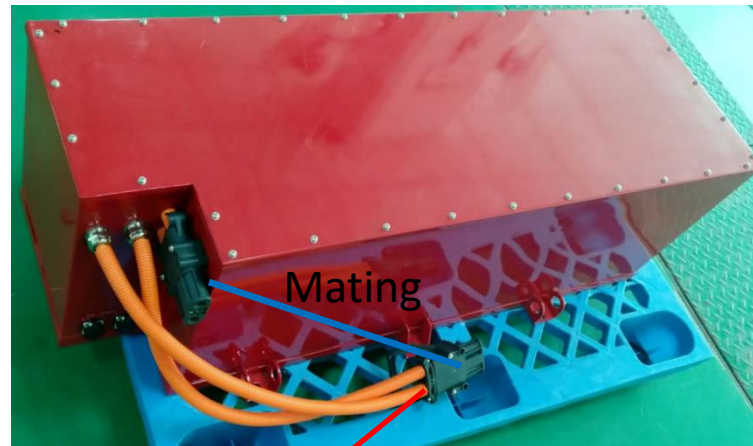

Mating

1. Meets DIN 43589-1 and EN1175-1 Standards
2. Low mating force
3. UL and CSA Recognized



OBC of E-Truck

Auxiliary DC Power

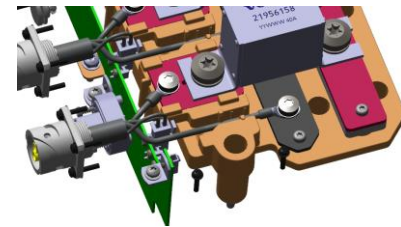
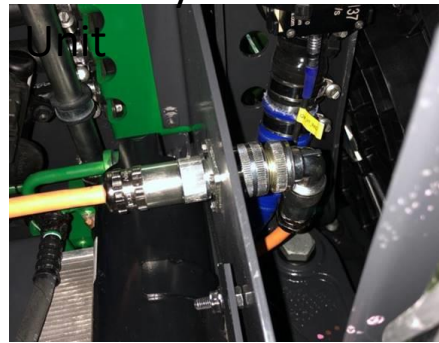
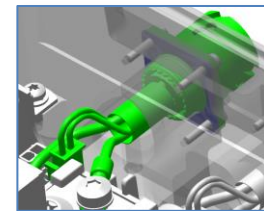

ePower-Lite

GT Series

## E-Truck

Application: DC/DC converter for electric and hybrid vehicle applications  
Volvo / Scania also MAN and Daimler will use this converter of Inmotion.  
Product: Customized GT



Customized  
GT for Power-  
in



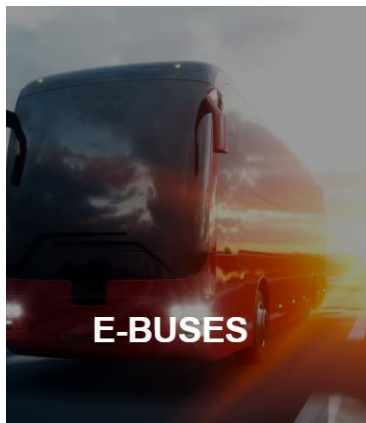

Product: Customize Surlok plus  
8.0mm  
Application: The battery of E-Bus



Customize Surlok  
plus



Irizar CCS



Application: e-Bus battery  
Product: UPC 9.1mm



UPC 9.1mm

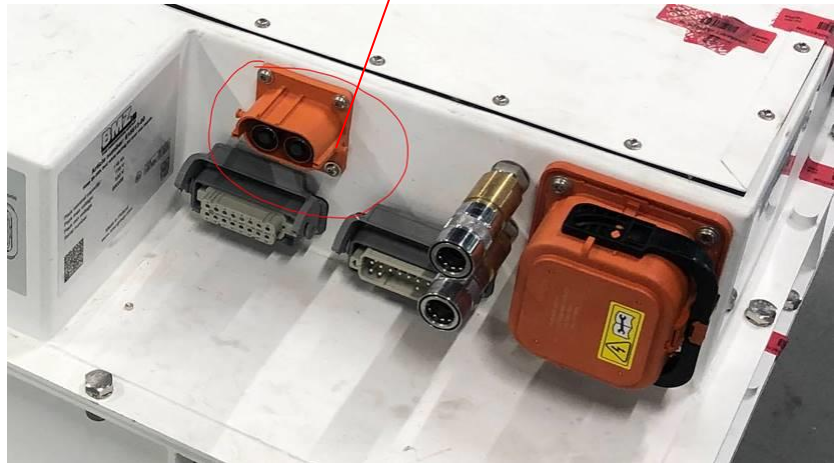

Application: PDU HV harness  
Product: HV and grounding cable harness

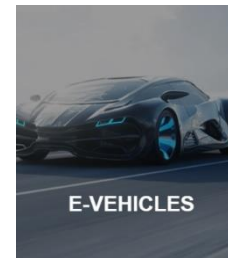

# PDU

- Product : PDU and cable harness.
- Low profile with 450v design for EV application.

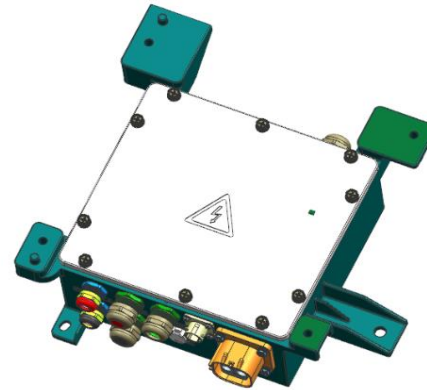
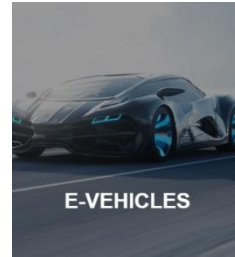
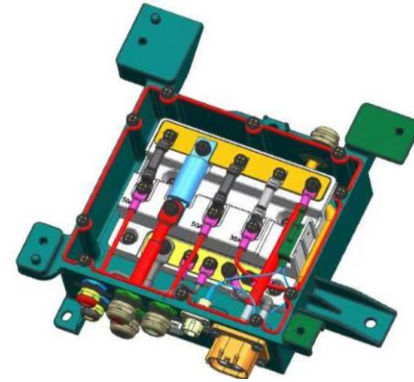

Customer: CUMMINS

Market: HEV

Application: Battery Pack

Product: LV and HV cable harness



Information is Amphenol Confidential & Proprietary. Do Not Reproduce or Distribute

[www.amphenol-industrial.com](http://www.amphenol-industrial.com)



Application: Power connection of PDU for the tractor of E-Agriculture Machinery.

Product: Surlok plus 5.7mm/8.0mm

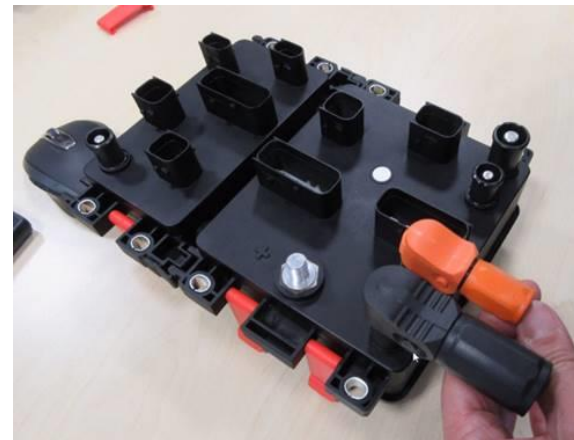
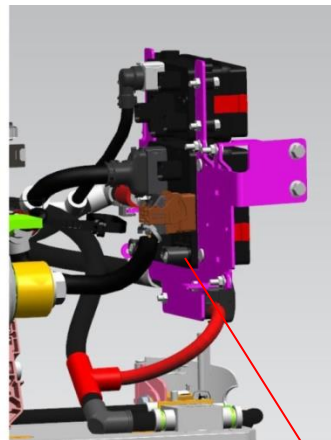
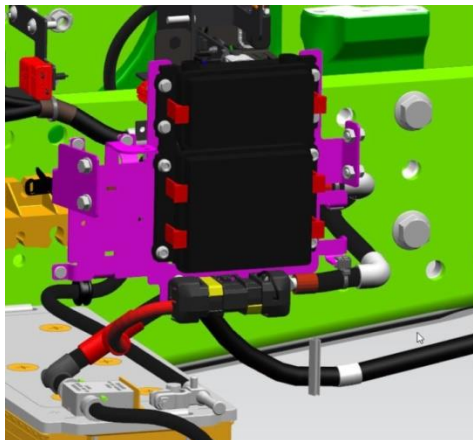
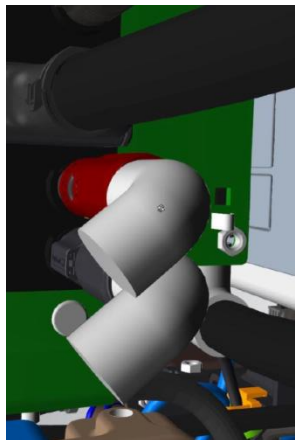

Surlok Plus

Application : The main harness interconnection for power supply coming from the battery of the tractor.

Product: Surlok plus 5.7mm

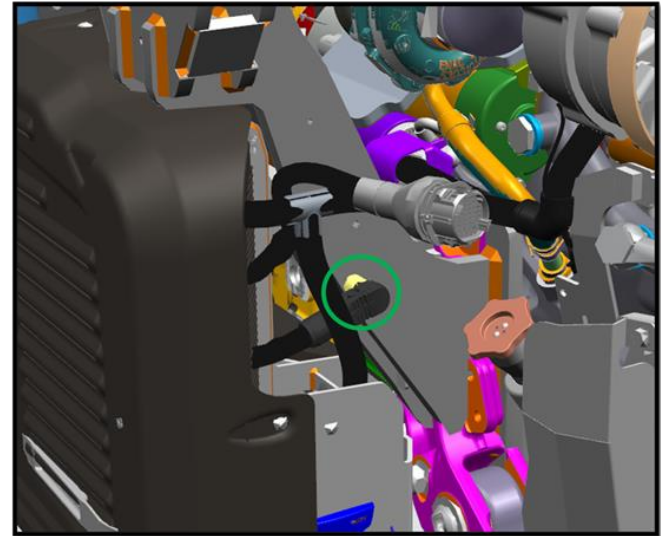

## Track solutions for E-CONSTRUCTION Product: Surlok plus 5.7mm/8.0mm.



Market: E-Boat  
Application : e- Foil Electric Water board  
Product: Surlok plus 5.7mm

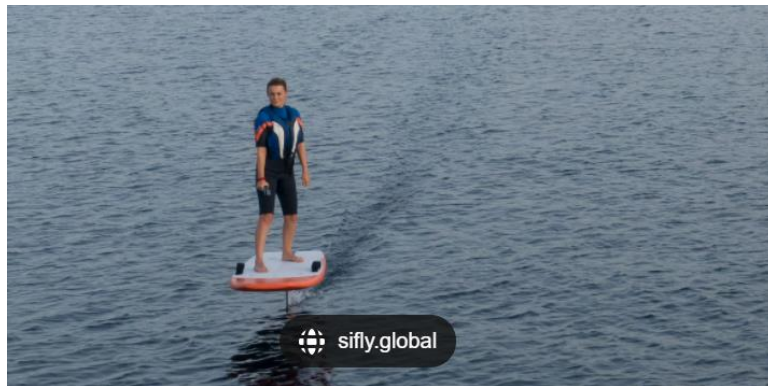

---

Market: E-Locomotive

Application: Battery System

Product: Customized UPC

---

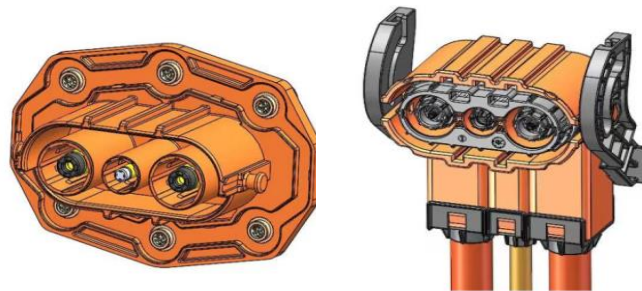

# THANKS!