Amphenol Tel-Ad

YOUR PARTNER FOR POWER AND CONNECTIVITY SOLUTIONS
2021

ATAD – Amphenol Tel-Ad

- Market leader - Solutions and Services provider in the fields of **Power Distribution, Electromechanics Interconnect, Connectors & Cable Assemblies, Wire Harnesses, Turn Key Projects** and more
- Center of Excellence for design and implementation of **Power Distribution and Complex Interconnect Solutions**
- Established 1986
- Location: Central Israel and Southern China
- Number of Employees: 450
- Size: 50,000 sqf – Israel / 55,000 sqf – China(6,000 sqf expansion potential)



ATAD Strengths

Vast knowledge and experience in designing and assembling Power and Electromechanical Cabinets, Cables and Complex Harnesses

- **Very Strong Engineering Team** supporting all stages of the product's life cycle: R&D, design and re-design to cost, design and re-design to manufacturability and more
- **Excellent NPI team** with proven experience in fast and efficient **transfer from R&D to Production** to support rapid Time-to-Market for our customers
- **Agile team** trained to support **quick turn-around** and Engineering Changes Implementations



ATAD Strengths / Continue

- Vast knowledge in developing **Testing Jigs and capabilities**
- Proven experience in **Sourcing** and **Manufacturing** in **Low Cost Regions** (ATAD China and other locations)
- The **Amphenol brand** and **Global Support**



All the above leads to, what we believe and consider as **Minimum Total Cost of Ownership**, of ATAD's solution to our customers



ATAD – Global Footprint / Global Logistics

HPI / ATAD Global Logistics and support model

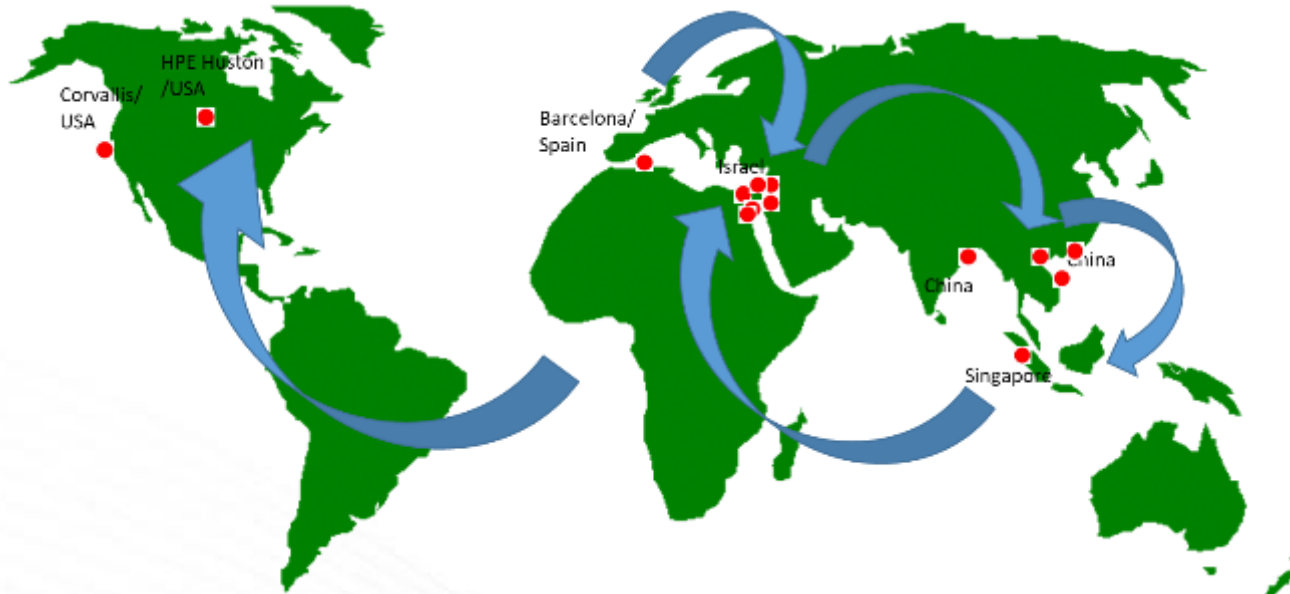

Partnership in Cambodia



AGIS Plant – Bangalore India



It's All about QUALITY !

International Quality Standards

- **ISO 9001:** (since 1995)
- **ISO 14001:** (since 2005)
- **AS 9100:** (Since May 2016)
- **ROHS Compliance:** (since 2006)
- **IPC 620** (cables workmanship standard): all Employees are certified.
- **CSA Approved Facility**
- **Safety standard:** UL/TUV (according to customers requirement)
- **Occupational Health and Safety** management systems



99.9%

Solutions – Product Mix

Amphenol Tel-Ad Solutions

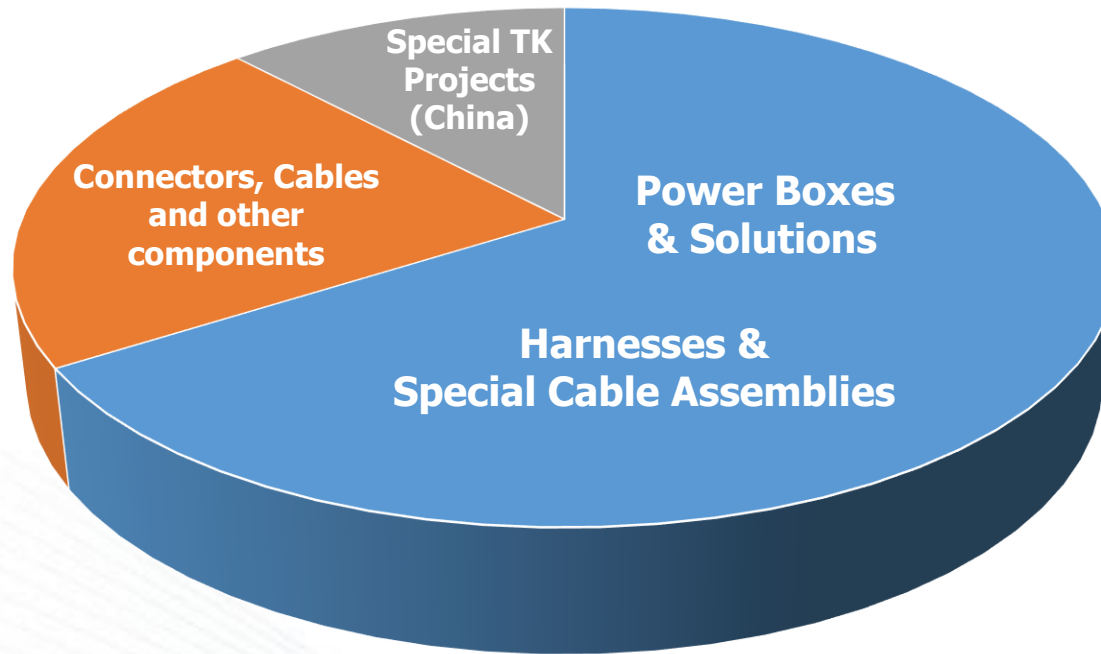

Solutions – Power Cabinets & Special Applications

- Amphenol Tel-Ad specialized in all types of PDU's (**P**ower **D**istribution **U**nits), including:
 - Build to spec. / print
 - Full turn-key design and manufacturing
 - Re-design to Cost / manufacturability / Quality
 - Multi- disciplinary Engineering support (Mechanical design, Thermal analysis and more)



Computer Controlled PDU

(*) for Super Computing Application

Project characteristics

- Collaborated Design
- Complete mechanical design
- Complete electrical Design
- Electronics design in collaboration with customer
- Thermal analysis and Tests
- Environmental Tests
- CSA certificate
- 480V/150A

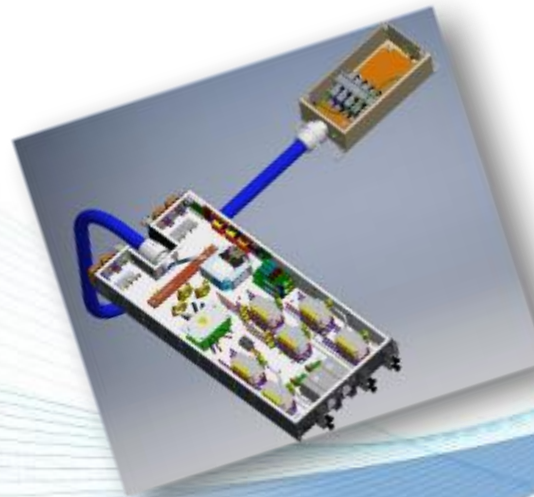

Full Turn-Key Interconnect and Power Solution

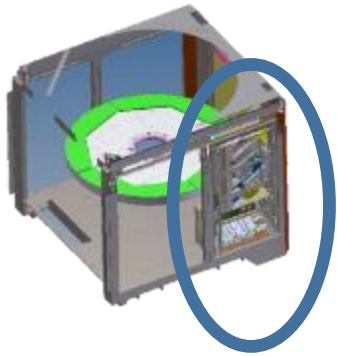

Innovative
Solutions

PDU for Laser Based System

Project Characteristics

- Redesign to Cost / Quality
- Complete Mechanical Design
- Electrical redesign
- 400V/100A
- 1100 connection points

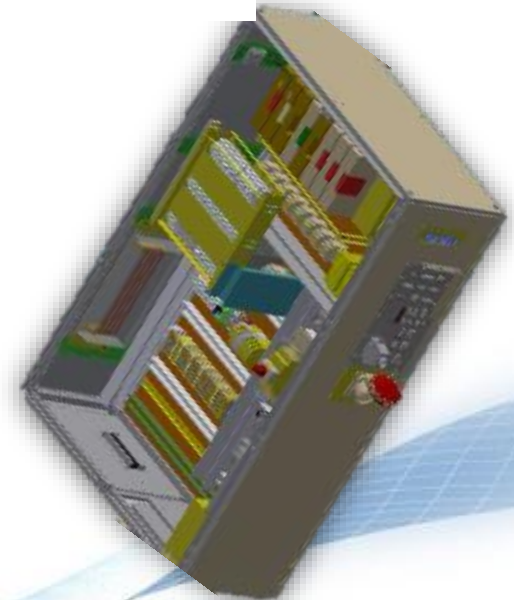
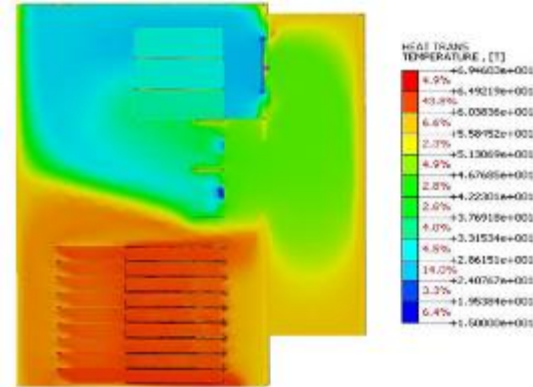

Solutions – PDU for Digital Printing System

Project Characteristics

- Design to Spec.
- Complete Mechanical Design
- Electrical design in collaboration with customer
- 400V/250A
- 2,600 connection points

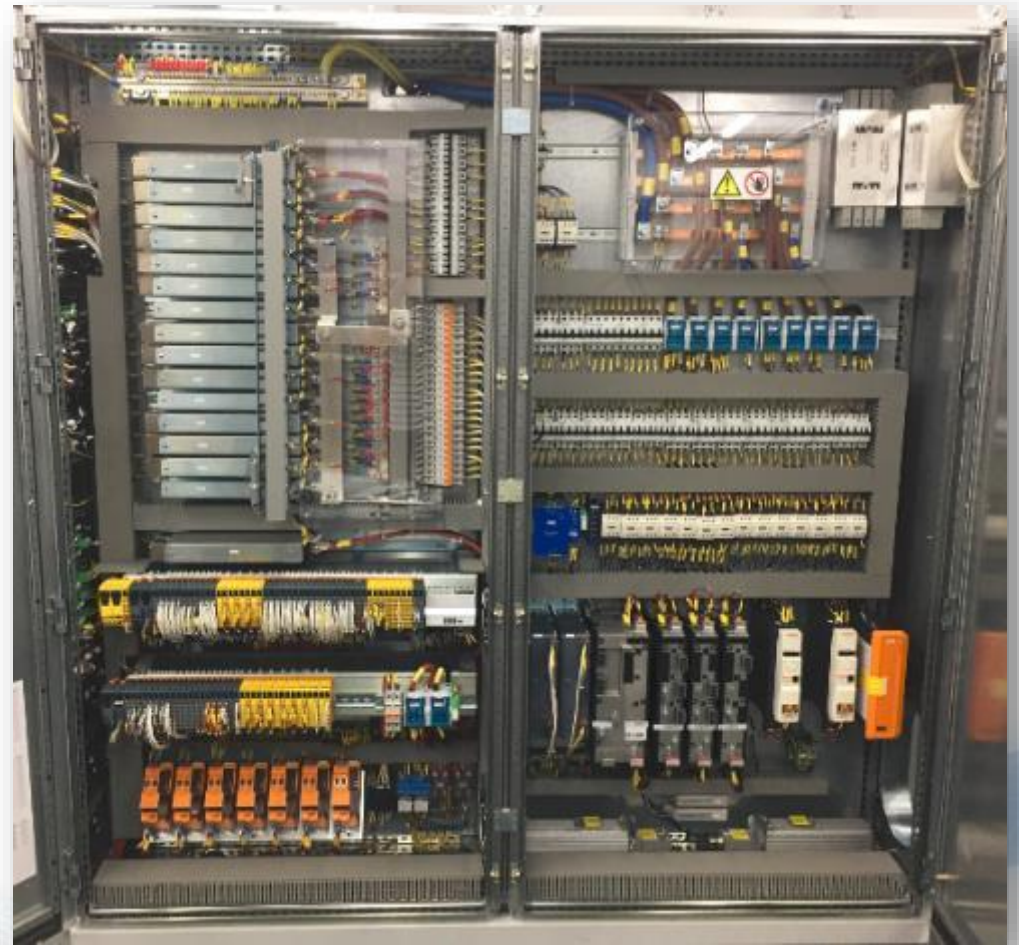

Solutions – Outdoor FTTH Cabinet

Project Characteristics

- Complete design by ATAD
- EIA, Bellcore GR-63-CORE (NEBS 2000), GR-1089-CORE and ETSI standards. heavy-duty frame
- EMC design per MIL-STD-461 10C 100A Solution
- EN61000 IP 55 TEST
- 27,000 cabinets installed in UK

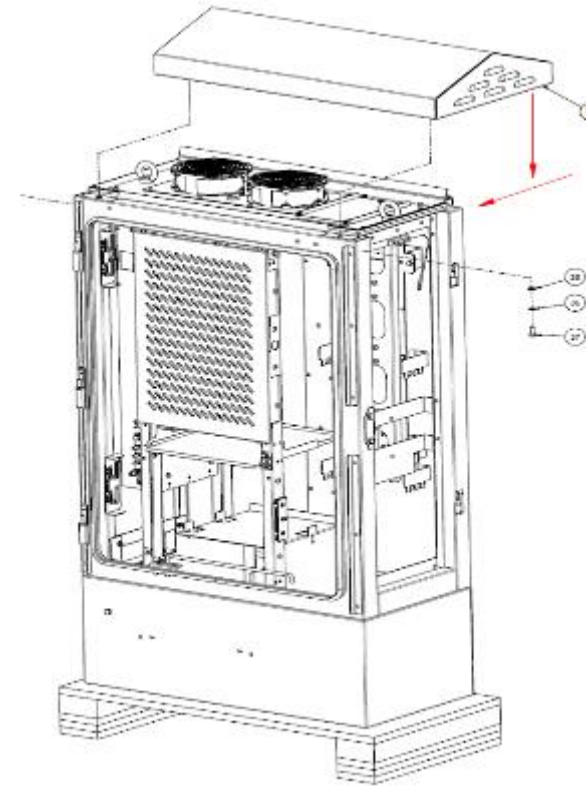

Solutions – PDU for MRI Medical System

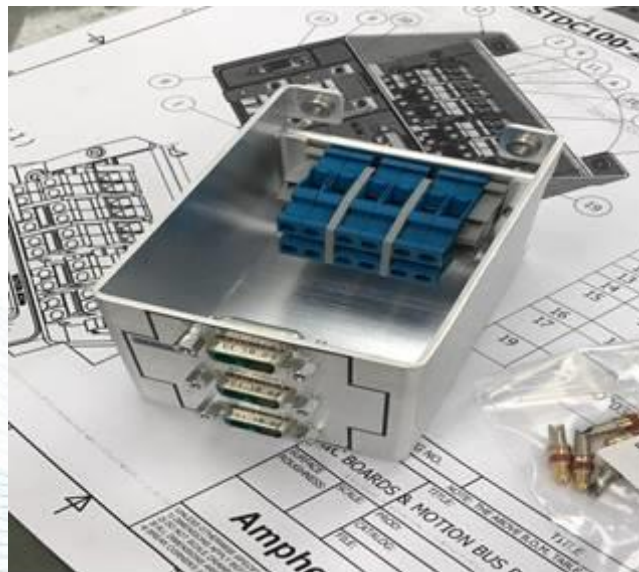
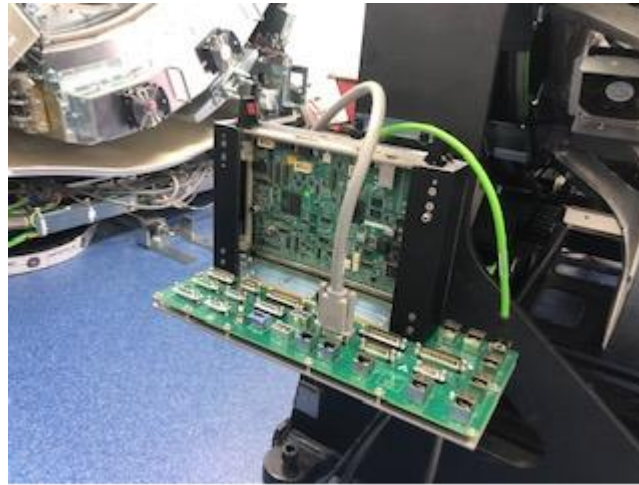

Solutions – PDU Panels for Digital Printing Apps

Project Characteristics

- Collaborated design
- Extremely fast Ramp-Up (Zero to 150 per month in less than one quarter)
- Fast Ramp-Up in parallel to extreme numbers of engineering changes / modifications

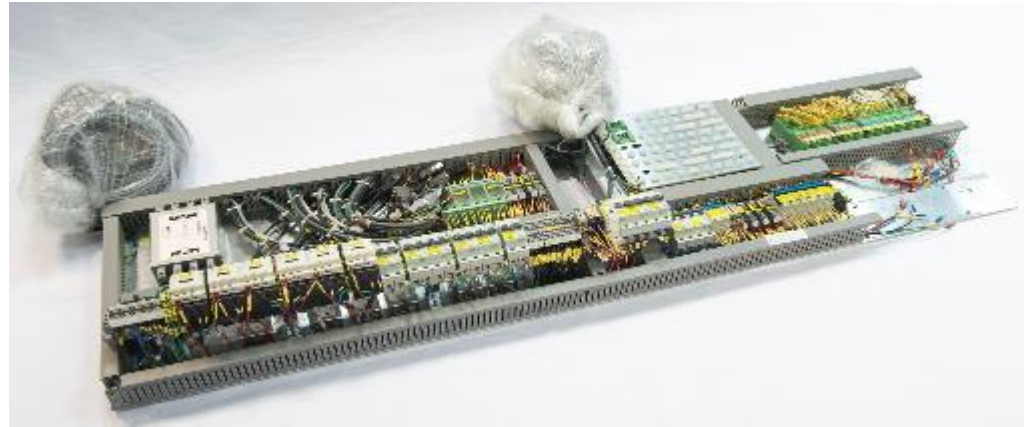

Developing your Rack Solutions

- ▶ Standard Racks
- ▶ Modifies Standard Racks
- ▶ Fully Custom Racks according to customers' requirements
- ▶ Completed over 300 different 19" products over the past 10 years, including:
 - ▶ NEBS Zone 4 certified racks
 - ▶ Outdoor and indoor cabinets



Solutions – Cable Assemblies and Harnesses

- Amphenol Tel-Ad specialized in all types of cabling solutions, including:
 - Design and assembly of complex harnesses
 - Design and manufacturing of molded cables
 - Design and assembly of custom-made integrated cables
 - Design and manufacturing/sourcing custom/standard connectors
 - R&D Support for system level concept design of cabling solutions

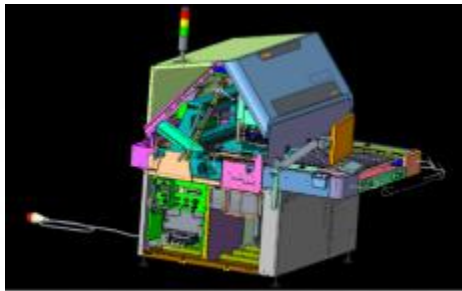

Cable to Harness Design

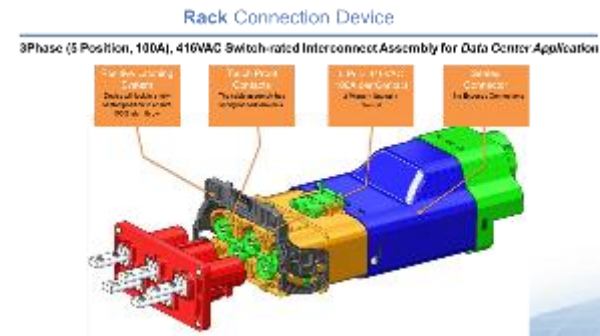

Solutions – Cable Assemblies and Harnesses

Amphenol Tel-Ad - Unique Capabilities and Solutions

- Design-in Amphenol's connectors portfolio for Industrial, Military, Medical and more
- Design and produce in according to customer requirements, specifications and applications
- Cross Reference manufacturing
- Production for price sensitive markets with Amphenol key partners in according to Amphenol standards

Amphenol Tel-Ad / AGIS is the only group in Amphenol which can use ANY SOURCE of raw-materials required for the customer's project and solution

Custom Power Solutions – RCD

Rack Connection Device

3Phase (5 Position, 100A), 416VAC Switch-rated Interconnect Assembly for *Data Center Application*

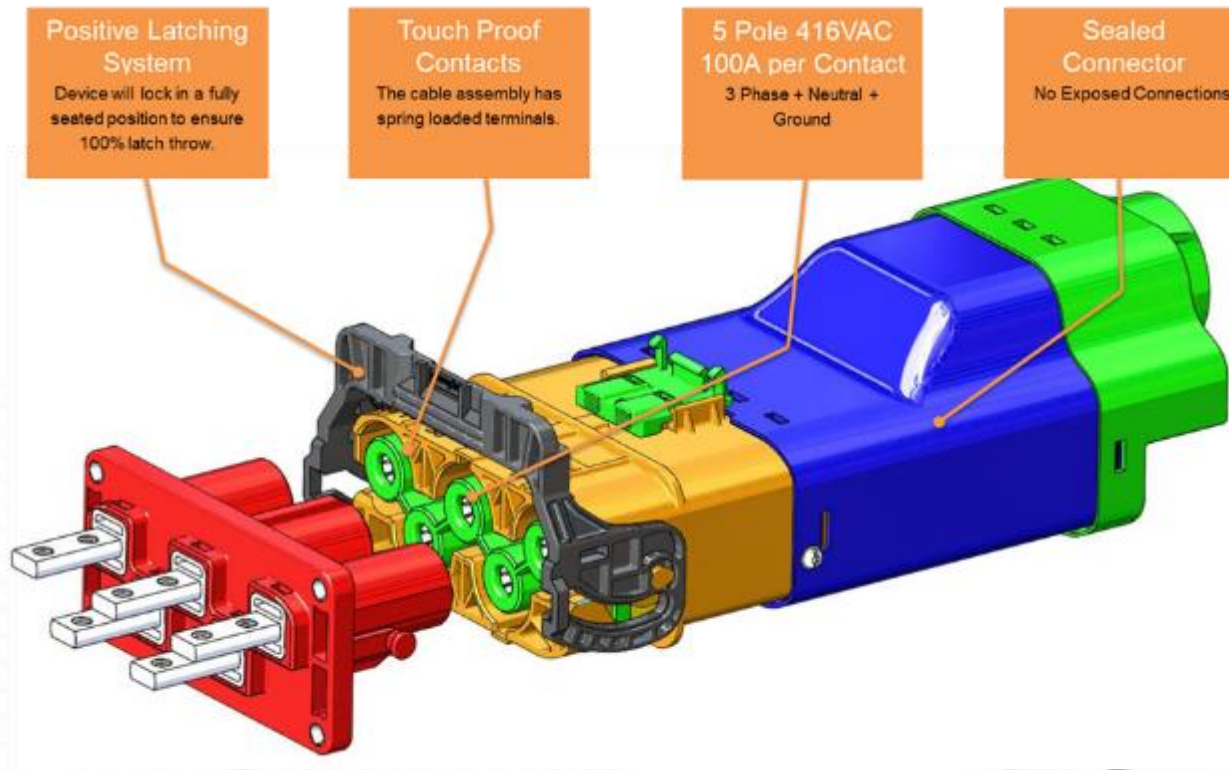

Custom Interconnect Solution – Cross Connect

Power and Signal combination all integrated into one



USB 3 custom module, high performance.

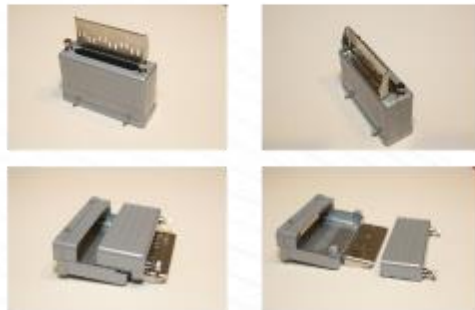

Amphenol Tel-Ad custom hood, easy for maint
Custom made cord grip.



Solutions – Robotic Harness for Medical Application

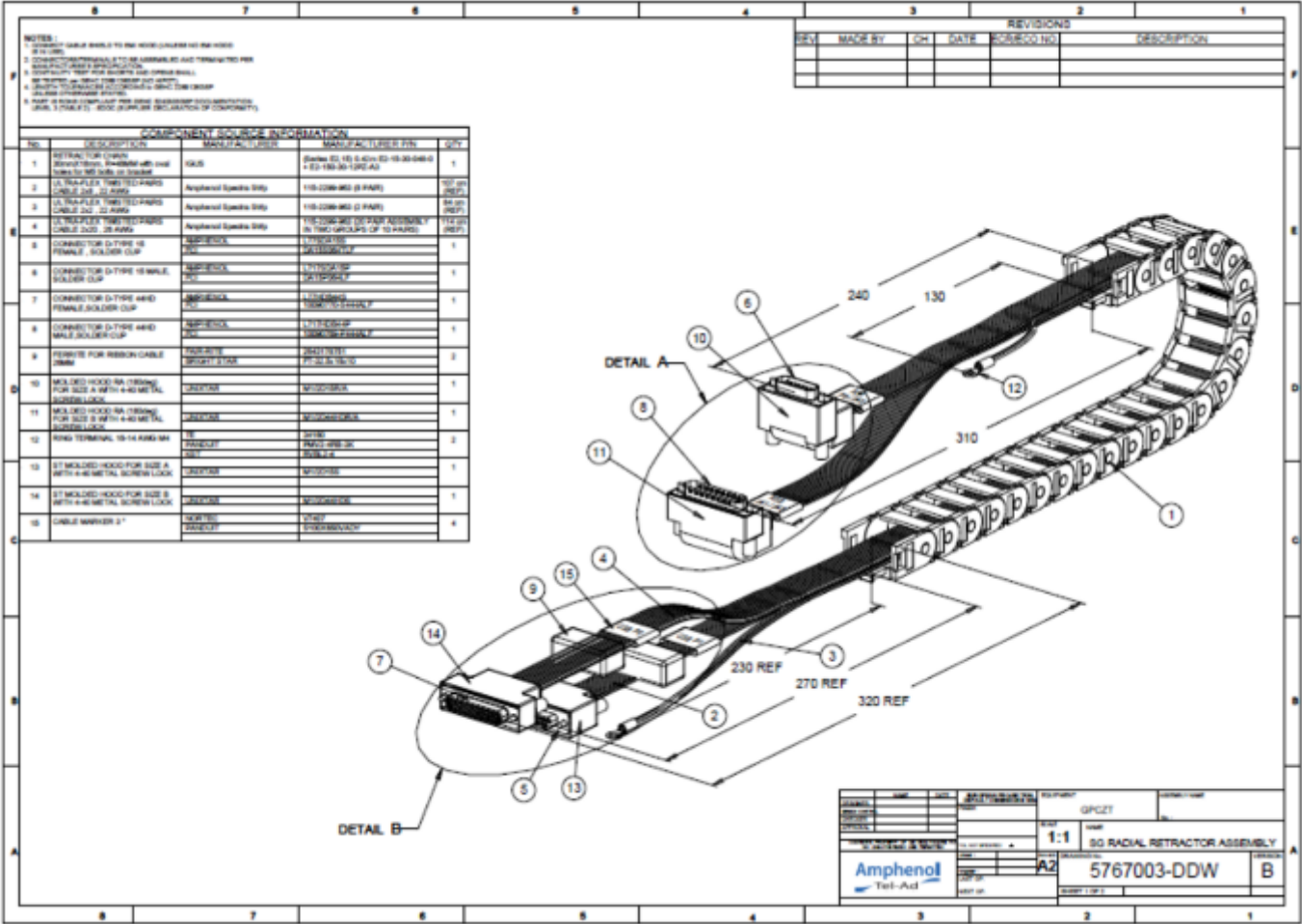

Solutions – Landa's Robotic Cable Track

Think Out of the Box

Design Challenge

Amphenol Solution

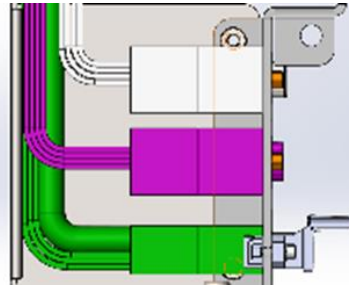
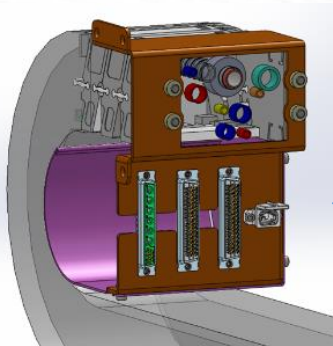
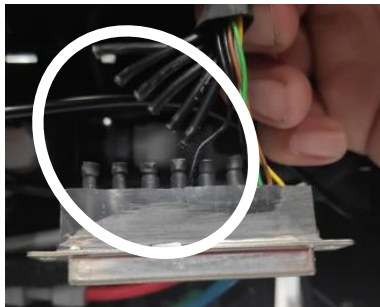
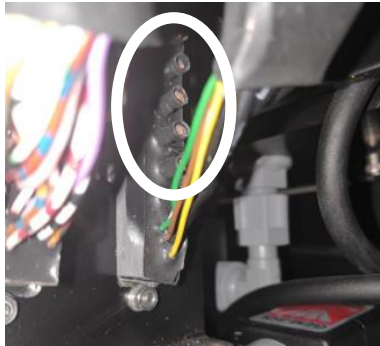

Few of our major Customers / Partners



Hewlett Packard
Enterprise

XJET



orbotech

SIEMENS

Ingenuity for Life



GE Healthcare



stratasys



Kornit
Digital

Landa



SPECTRUM
DYNAMICS MEDICAL

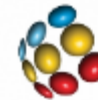

SCODIX

Highcon

Direct To Pack



Mellanox[®]
TECHNOLOGIES



LUMENIS[™]

Enhancing Life. Advancing Technology.

CORNING

Mazor
Robotics

flex

LIVE SMARTER

SANMINA



efi[™]

CERAGON

Amphenol
Tel-Ad

4 Pillars to Success

